

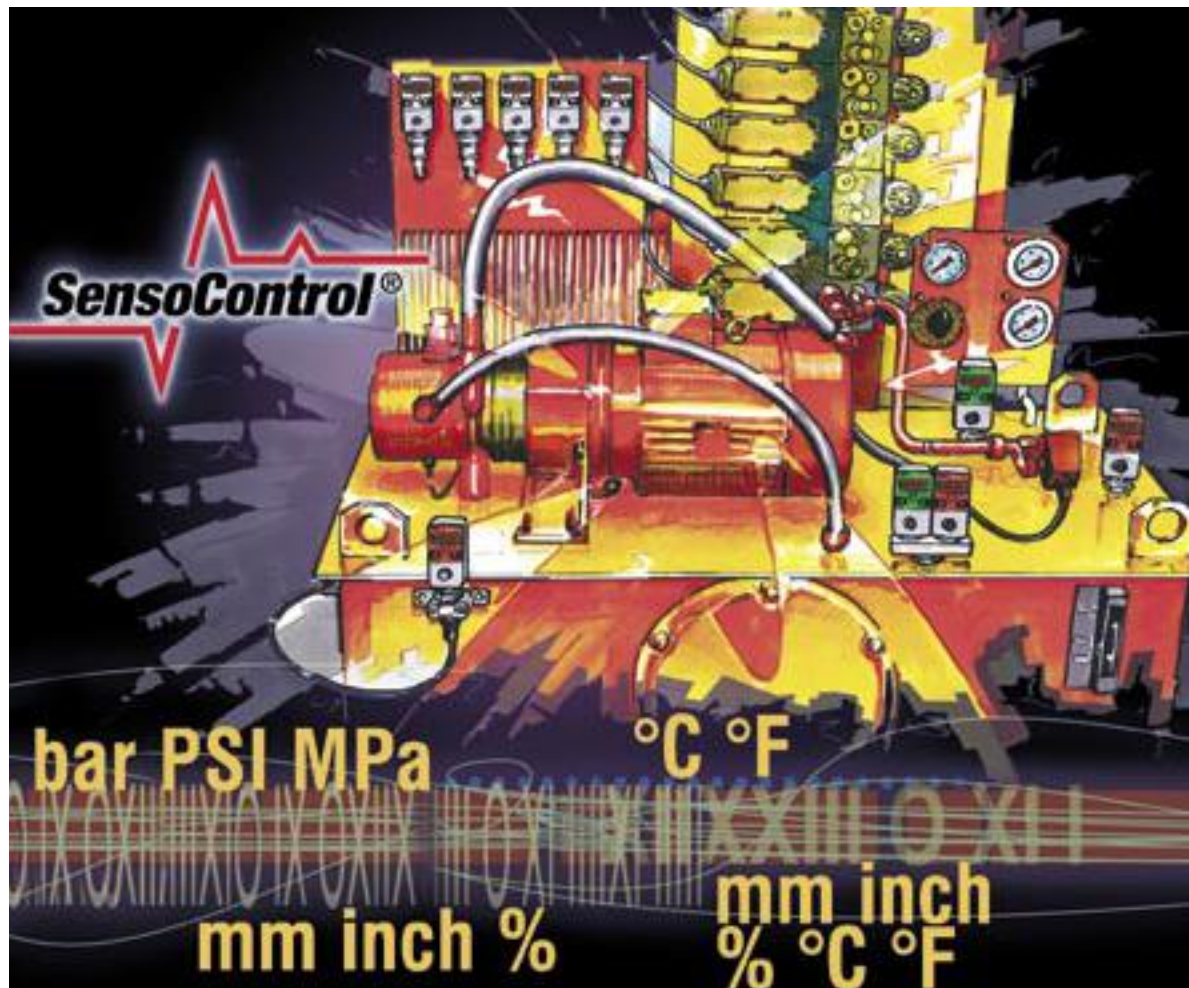

Measurement, Control, Regulation and Automation

Catalogue 4083-2/UK





The CE mark indicates high-quality equipment which meets European Directives 89/336/EEG and EMVG requirements respectively. It is hereby confirmed that the products are in accordance with the following standards:

Electromagnetic compatibility

Electromagnetic interference emissions:
EN 61000-6-3
Electromagnetic interference resistance:
EN 61000-6-2

Important

- Electromagnetic interference can influence the useful signal.
- General EMC concepts should be used in the designing of installations and machinery.
- To achieve better EMC interference resistance, the deployment of screened connecting cables is recommended (SCK-400-xx-x5).
- Route analogue and data cables at a safe distance from power cables.
- A perfect earthing arrangement helps to avoid measurement errors.

Always connect the metallic housing with the laid-down quantities. The PE protective earth terminal should be connected up with a low ohm value. Measurement of the protective earth resistance should take place in accordance with VDE 0701.

Power supply

The recommended power supply with which each standard sensor should be driven is indicated for the individual sensor series. A low-noise, high quality, constant voltage source is recommended. Some specifications, such as sensitivity and thermal sensitivity shift, change if a supply voltage is used which is not recommended. Every sensor is tuned to give peak performance. Usage with any other than the indicated power supply leads to a change in sensor performance. All polarity and earthing regulations should be strictly followed.



Improper connection of the supply wires can cause damage to the sensor or amplifier! If one pole of the sensor supply voltage is earthed automatically by a signal processing system, a simultaneous earthing of one of the sensor signal wire should be avoided; this would short-circuit the sensor and thereby lead to damage.



Do not connect a power supply to the output wires; this would lead to permanent damage to the sensor! Exceeding the maximum recommended supply voltage indicated in the data sheet would also lead to sensor damage!

Media compatibility

SensoControl® products in contact with media are not produced in an oil and grease-free environment. Therefore these products should **not** be used for applications where an explosive oil or oil/gas mixture could occur (eg. acid or compression). (Danger of explosion!) Use only those media which are compatible with the parts in contact with the media (see data sheets). If you should have any questions, please refer to the installation manufacturer or to the manufacturer of the medium being used (see catalogue 4100 chapter C).

Selection of pressure range

When selecting pressure elements do not exceed the overload pressure P_{max} . If the overload pressure P_{max} is exceeded, mechanical deformation of the pressure cell (according to the length/ frequency and height of the pressure peak) can result. Note: where there are air inclusions, because of the "diesel effect" pressure peaks can occur which far exceed the overload pressure. The nominal pressure PN of the pressure element (sensor/switch) should lie above the nominal pressure of the system being measured.

Failure to follow this rule can adversely affect the functional safety and reliability of products, cause personal injury, property damage, and result in loss of your guarantee rights.
Subject to alteration.

	Page
Index	4
Product overview	5
1. Pressure and temperature sensors	6-17
1.1 SCP Mini pressure sensors	8-10
1.2 SCP-EX pressure sensors	11-13
1.3 SCP-MO pressure sensors	14-15
1.4 SCP-MO temperature sensor SCP-MO	16-17
2. Volume flow sensors	18-33
2.1 SCQ flow rate meter	20-23
2.2 SCFT measurement turbine	24-27
2.3 SCVF volume counter	28-33
3. Digital display units	34-37
3.1 SCE-020 digital display unit	34-37
4. The Controller family	38-75
4.1 SCPSD PressureController	40-45
4.2 SCTSD TemperatureController	46-47
4.2.1 SCTSD Modular TemperatureController	48-53
4.2.2 SCTSD high pressure TemperatureController	54-57
4.3 SCLSD LevelController	58-63
4.4 SCLTSD LevelTempController	64-69
4.5 SCOTC OilTankController	70-75
5. Accessories	76-81
5.1 SCK cable	76-77
5.2 SCA adaptor	78-79
5.3 ControllerWIN software	80-81
6. Installation and safety advice	82
6.1 EMC	82
6.2 Media compatibility	82
6.3 Selection of pressure range	82

SCxSD	38-39	SCK-410-03-45-45	52	SCPSD-xxx-14-15	40-45
SC-910	23	SCLSD-xxx-00-07	58-63	SCPSD-xxx-14-17	40-45
SC-911	23	SCLSD-xxx-10-05	58-63	SCPSD-xxx-14-25	40-45
SC-912	23	SCLSD-xxx-10-07	58-63	SCPSD-xxx-14-27	40-45
SCA-1/2-EDX-1/4-D	78	SCLTSD-xxx-00-07	64-69	SCQ-060-10-07	20-23
SCA-1/4-ED-1/2-ED	78	SCLTSD-xxx-10-05	64-69	SCQ-150-10-07	20-23
SCA-1/4-EDX-1/4-D	78	SCLTSD-xxx-10-07	64-69	SCQ-M23x1.5-ED	23
SCA-1/4-M22x1.5-ED	78	SCOTC-xxxx-00-05	70-75	SCQ-M42x1.5-ED	23
SCAF-1/4-40	79	SCOTC-xxxx-00-07	70-75	SCQ-R1/2-ED	23
SCAF-3/4-90	79	SCOTC-xxxx-10-05	70-75	SCQ-R3/4-ED	23
SCAQ-060	20-23	SCOTC-xxxx-10-07	70-75	SCSD-PRG-KIT	80-81
SCAQ-150	20-23	SCP-xxx-14-06	8-10	SCSD-S27	44/52
SCAQ-GI-R1/2	20-23	SCP-xxx-14-06	8-10	SCSN-410	34-37
SCA-TT-10-xxx	52	SCP-xxx-14-07	8-10	SCT-150-14-00	16-17
SCA-TT-10-1/2	52	SCP-xxx-14-07	8-10	SCTSD-150-00-06	46-53
SCE-020-02	34-37	SCP-xxx-24-06	8-10	SCTSD-150-00-07	46-53
SCFT-xxx-32-07	24-27	SCP-xxx-24-07	8-10	SCTSD-150-02-07	54-57
SCK-006	76-77	SCP-xxx-34-06	8-10	SCTSD-150-10-05	46-53
SCK-145	76-77	SCP-xxx-34-06-EX	11-13	SCTSD-150-10-07	46-53
SCK-155	76-77	SCP-xxx-34-07	8-10	SCTSD-150-12-05	54-57
SCK-300-02-31	34-37	SCPSD-xxx-04-16	40-45	SCTSD-150-12-07	54-57
SCK-400-xx-45	76-77	SCPSD-xxx-04-17	40-45	SCTT-10-xxx-07	51
SCK-400-xx-55	76-77	SCPSD-xxx-04-26	40-45	SCTT-20-10-07	51
SCK-400-xx-56	76-77	SCPSD-xxx-04-27	40-45	SCVF-xxx-10-07	28-32

Old order code**New order code**

SCK-007	SCK-145
SCK-045	SCK-145
SCK-047	SCK-145
SCK-055	SCK-155
SCK-057	SCK-155
SCK-147	SCK-145
SCK-157	SCK-155
SCK-200-xxx-45	SCK-400-xxx-45
SCK-200-xxx-47	SCK-400-xxx-45
SCK-200-xxx-55	SCK-400-.55
SCK-200-xxx-56	SCK400-xxx-56
SCK-200-xxx-57	SCK-400-.55
SCK-400-xxx-06	SCK-400-xxx-56
SCK-400-xxx-07	SCK-400-xxx-45
SCK-400-xxx-47	SCK-400-xxx-45
SCK-400-xxx-57	SCK-400-.55
SCPSD-xxx-04-05	SCPSD-xxx-04-17
SCPSD-xxx-04-06	SCPSD-xxx-04-16
SCPSD-xxx-04-07	SCPSD-xxx-04-17
SCPSD-xxx-14-05	SCPSD-xxx-14-15

Old order code**New order code**





SCP-xxx-10-06	SCP-xxx-14-06 + SCA-1/4-M22x1.5-ED
SCP-xxx-10-07	SCP-xxx-14-07 + SCA-1/4-M22x1.5-ED
SCP-xxx-12-06	SCP-xxx-14-06 + SCA-1/4-ED-1/2-ED
SCP-xxx-12-07	SCP-xxx-14-07 + SCA-1/4-ED-1/2-ED
SCP-xxx-20-06	SCP-xxx-24-06 + SCA-1/4-M22x1.5-ED
SCP-xxx-20-07	SCP-xxx-24-07 + SCA-1/4-M22x1.5-ED
SCP-xxx-22-06	SCP-xxx-24-06 + SCA-1/4-ED-1/2-ED
SCP-xxx-22-07	SCP-xxx-24-07 + SCA-1/4-ED-1/2-ED
SCP-xxx-30-06	SCP-xxx-34-06 + SCA-1/4-M22x1.5-ED
SCP-xxx-30-07	SCP-xxx-24-07 + SCA-1/4-M22x1.5-ED
SCP-xxx-32-06	SCP-xxx-34-06 + SCA-1/4-ED-1/2-ED
SCP-xxx-32-07	SCP-xxx-24-07 + SCA-1/4-ED-1/2-ED
SCP-xxx-40-06	SCP-xxx-44-06 + SCA-1/4-M22x1.5-ED
SCP-xxx-40-07	SCP-xxx-44-07 + SCA-1/4-M22x1.5-ED
SCP-xxx-42-06	SCP-xxx-44-06 + SCA-1/4-ED-1/2-ED
SCP-xxx-42-07	SCP-xxx-44-07 + SCA-1/4-ED-1/2-ED

Please enquire about compatible products for items not listed..



Product overview

Measure:

pressure and temperature sensors

SCP (Mini)	SCT-150-14-00	SCP-MO (Mobil)	SCP-EX (EX explosion protection)
			
✓ pressure measurement for standard applications	✓ temperature measurement even for higher working pressures	✓ pressure measurement for mobile hydraulics	✓ pressure measurement in EEx ia areas
pages 8-10	pages 16-17	pages 14-15	pages 11-13

volume flow sensors

SCQ	SCFT	SCVF
		
✓ for quickly changing volume flows ✓ measurement in both directions	✓ low loss volume flow measurement	✓ measurement in various media ✓ measurement of low volume flows (leakage measurement)
pages 20-23	pages 24-27	pages 28-33

Display:

SCE Display units



pages 34-37

Measure & display & switch:

the Controller family

PressureController	TemperatureController	LevelController	LevelTempController	OilTankController
				
✓ pressure display and monitoring	✓ temperature display and monitoring	✓ level display and monitoring	✓ level and temperature display and monitoring	
pages 40-45	pages 46-57	pages 58-63	pages 64-69	pages 70-75

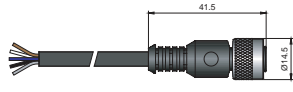
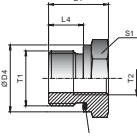
Accessories:

SCK cable	SCA adaptor	ControllerWIN software
		
pages 76-77	pages 78-79	pages 80-81

1. Pressure and temperature sensors

- ✓ **Stable long-term**
- ✓ **Interference resistant**
- ✓ **Ruggedly constructed**
- ✓ **Reliable**

The main features of **SensoControl**[®] sensors are long-term stability, resistance to interference, rugged construction, availability in a wide range of versions and high quality standards.

Bearing in mind established standards in industrial measurement and control technology, these sensors are developed and manufactured in our own production facilities. Because of this, it is easy to meet individual customer requirements or critical applications.

Furthermore, the special requirements of the automation and mobile hydraulics sectors respectively were taken into account at the design stage. This is why **SensoControl**[®] sensors are ideally suited to permanent series installation in industrial and mobile applications.

Pressure sensors









The housing and all the parts of the pressure sensors in contact with the media are made from stainless steel and because of this, offer wide media resistance. The combination of their lack of sensitivity to external influences such as shock, vibration and temperature with their interference resistance, results in a wide spectrum of applications.

Their operative range extends from test stands through to process technology, materials-handling and lifting technology, mobile hydraulics, general machinery construction and on to pneumatic and hydraulic plant construction.

If pressure is to be measured on a long-term and reliable basis, then the SCP is the one to be used. In this connection, the optimum sensor type can be selected from the Mini, Mobile and Ex series, according to the application. Also available, of course, are various plug-in connectors, output signals and connecting threads.

Temperature sensors

If a temperature signal is required, the SCT temperature sensor is the one to select. It has an outstanding and unique pressure resistance of 630 bar.

	SCP (Mini)	SCT	SCP-MO (Mobil)	SCP-EX (EX-protection)
Applications				
	pressure measurement for standard applications	temperature measurement even at higher working pressures	pressure measurement in mobile hydraulics	pressure measurement in potential explosion areas
	<ul style="list-style-type: none"> ✓ stainless steel cell ✓ small construction ✓ high burst pressure ✓ resistant to pressure peaks ✓ shock and vibration-proof 	<ul style="list-style-type: none"> ✓ unique pressure resistance up to 630 bar ✓ compact ✓ standard output signal ✓ rapid reaction time 	<ul style="list-style-type: none"> ✓ stainless steel cell ✓ small construction ✓ high burst pressure ✓ resistant to pressure peaks ✓ shock and vibration-proof ✓ load dump protection 	<ul style="list-style-type: none"> ✓ stainless steel cell ✓ small construction ✓ high burst pressure ✓ resistant to pressure peaks ✓ shock and vibration-proof 
Measurement range	4/6/10/16/25/40/60/100/160/250/400/600 bar	-50...+125 °C	-1...+1 bar up to 0...4000 bar	1,0/1,6/2,5/4/6/10/16/25/40/60/100/160/250/400/600/1000/1600/2000 bar
Connection to the medium	G1/4 BSPP	M10x1	G1/4 BSPP others on request	G1/4 BSPP
Accuracy	< ± 0,5 % FS	< ± 2 % FS	< ± 0,5 % FS	< ± 0,5 % FS
Electrical connection	M12x1; DIN EN175301-803 Form A	3 m cable	fixed cable plug: AMP Packard Deutsch M12x1 etc.	DIN EN 175301-803 Form A
Electrical output	0...20 mA; 3-core 4...20 mA; 2-core 4...20 mA; 3-core 0...10 V; 3-core	0...20 mA; 3-core	4...20 mA 1...5/1...6/0...10 V 0,5...4,5 V ratiometric PWM etc.	4...20 mA; 2-core
Applications	from test stands to process technology, through handling/lifting technology, general machine construction on to pneumatic and hydraulic plant construction		mobile hydraulics/ industrial trucks/materials handling trucks/commercial vehicles	water technology/hydraulics heating technology pneumatics/industrial robots climate control technology/ process control test technology
				
Order codes	SCP-xxx-x4-0x	SCT-150-14-00	SCP-xxx-x4-0x- MO	SCP-xxx-34-06- EX
See pages	8-10	16-17	14-15	11-13

1.1 SCP Mini pressure sensors

- ✓ **Stainless steel cell**
- ✓ **Small construction**
- ✓ **High burst pressure**
- ✓ **Resistant to pressure peaks**
- ✓ **Shock and vibration-proof**
- ✓ **Wide media resistance**
- ✓ **High linearity**
- ✓ **Long-term stability**

The Mini-SCP pressure sensor was designed for industrial application requirements and is used in control, regulation and monitoring systems where rapid pressure-dependent analogue signals are needed.

The SCP-Mini pressure sensor is outstanding because of its compact construction, high linearity and excellent interference resistance.



Construction

The SCP-Mini includes only a few active components – the sensor element, a signal-processing ASIC and a converter switch.

The ASIC is a programmable precision CMOS-ASIC with EEPROM data memory and analogue signal path, which is qualified for an extended working temperature range. Because of electronic calibration, a small total error and high long-term stability are achieved. The electronics are resistant to the effects of electromagnetic interference. Pressure is captured with a zero-point and long-term stable measurement cell.

The hermetically welded stainless steel membrane is vacuum tight and highly resistant to bursting.

The standardised G1/4 BSPP corrosion-resistant stainless steel process connection, in so far as it is compatible with stainless steel, guarantees wide-ranging media resistance.

Applications

Plenty of electrical output signals and plug-in connectors guarantee a wide spectrum of applications.

This sensor is eminently suitable for permanent series usage in hydraulic and pneumatic applications, thanks to its long durability, high accuracy, high reliability and rugged stainless steel construction.

SCP Mini	004	006	010	016	025	040	060	100	160	250	400	600
pressure range * P_N (bar)	0...4	0...6	0...10	0...16	0...25	0...40	0...60	0...100	0...160	0...250	0...400	0...600
overload pressure P_{max} (bar)	2 times											
burst pressure P_{Burst} (bar)	3- times											2,5-times

Pressure connection	
pressure connection	G1/4A BSPP DIN 3852 T11, form E
erosion bore	0,6 mm ED-seal FKM
Material	
parts in contact with media	FKM; stainless steel 1.4542,1.4548; 17-4PH
housing	stainless steel 1.4301
protection class	IP67 DIN EN 60529 (with DIN EN 175301-803 form A plug IP65)
Plug-in connection	
4-pole; M12x1; IP67	
4-pole; DIN EN 175301-803 form A; IP65	
Electrical connection	
short circuit protect'n; reverse polarity protect'n; protect'n class 3	
Accuracy	
characteristic curve deviation	± 0,5 % FS start point setting
General	
response time	≤ 1 ms
long-term stability	< 0,1 % FS/a
weight	ca. 80 g
load reversals	≥ 20 Mio.

Environmental conditions	
environmental temperature range	-40...+85 °C
fluid temperature range	-40...+125 °C
compensated range	-20...+85 °C
storage temperature	-40...+125 °C
temperature coefficient	≤ ± 0,3 % FS/10 K
vibration resistance	IEC 60068-2-6; ± 5 mm; 10 Hz...32 Hz 200 m/s ² ; 32 Hz...2 kHz
shock resistance	IEC 60068-2-29: 500 m/s ² ; 11 ms IEC 60068-2-32: 1 m (free fall onto steel plate)
Electromagnetic compatibility	
interference emissions	DIN EN 61000-6-3
interference resistance	DIN EN 61000-6-2

Output signal	0...20 mA 3-core	4...20 mA 3-core	4...20 mA 2-core	0...10 V 3-core
auxiliary energy + U_b (U_{DC})	9...30 V	9...30 V	12...30 V	12...30 V
working resistance max.	(U_b -9 V)/28 mA	(U_b -9 V)/30 mA	(U_b -12 V)/20 mA	35 kΩ

* see page 82, 6.3

DIN EN 175301-803 form A (formerly DIN 43650) plug-in connector



PIN	0...20 mA 3-core	4...20 mA 3-core	4...20 mA 2-core	0...10 V 3-core
1	P signal	P signal	P signal	P signal
2	0 V (GND)	0 V (GND)	n.c.	0 V (GND)
3	+U _b	+U _b	+U _b	+U _b
grounding conductor connection (not connected; must not be occupied!)				

M12 plug-in connector

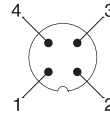

PIN	0...20 mA 3-core	4...20 mA 3-core	4...20 mA 2-core	0...10 V 3-core
1	+U _b	+U _b	+U _b	+U _b
2	P signal	P signal	P signal	P signal
3	0 V (GND)	0 V (GND)	-	0 V (GND)
4	-	-	-	-

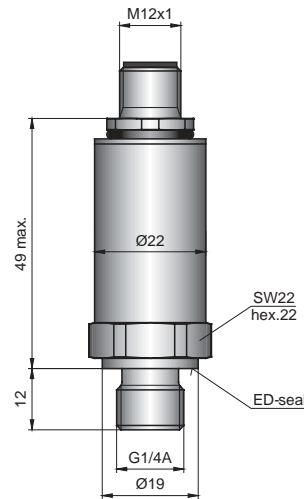
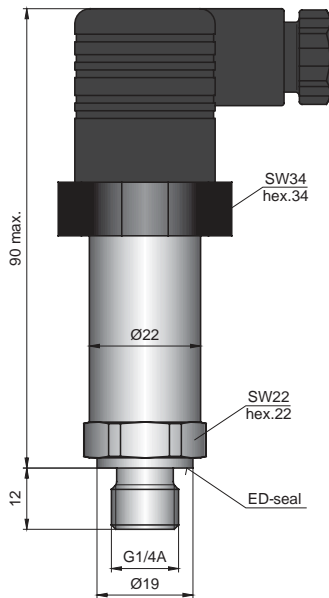

Order codes

Pressure range *

004; 006; 010; 016; 025;
040; 060; 100; 160, 250;
400; 600 bar

DIN EN 175301-803 form A, G1/4 BSPP, class 0.5 %

0...20 mA; 3-core
4...20 mA; 3-core
4...20 mA; 2-core
0...10 V; 3-core

SCP-xxx-14-06
SCP-xxx-24-06
SCP-xxx-34-06
SCP-xxx-44-06

M12 plug-in connector, G1/4 BSPP, class 0.5 %

0...20 mA; 3-core
4...20 mA; 3-core
4...20 mA; 2-core
0...10 V; 3-core

SCP-xxx-14-07
SCP-xxx-24-07
SCP-xxx-34-07
SCP-xxx-44-07

* see page 82, 6.3

Connecting cables and separate plugs

Connecting cable, made up

(open cable end)

Cable length in m

- 02 2 m
- 05 5 m
- 10 10 m

Plug-in connector

- 45 M12 cable socket; straight
- 55 M12 cable socket; 90° angled
- 56 DIN EN 175301-803 Form A plug connector (alt DIN 43650)

Separate plugs

- M12 cable socket; straight
- M12 cable socket; 90° angled
- DIN EN 175301-803 Form A plug connector (old DIN 43650)

SCK-400-xx-xx

SCK-145
SCK-155
SCK-006

1.2 SCP-EX Pressure sensors

- ✓ Rugged
- ✓ Stable long-term
- ✓ Reliable
- ✓ Stainless steel
- ✓ EEx ia



The SCP-EX pressure sensor was designed for explosion-risk applications (II 2G EEx ia IIC T4) and is used in control, regulation and monitoring systems where pressure-dependent analogue signals are needed.

The SCP-EX pressure sensor is outstanding for its compact construction, high linearity and excellent resistance to interference.

Construction

The SCP-EX includes only a few active components – the sensor element, a signal-processing ASIC and U/I converter switching.

The ASIC is a programmable precision CMOS-ASIC with EEPROM data memory and analogue signal path, which is qualified for an extended temperature range. Because of its electronic calibration, a small total error and high long-term stability is achieved. The electronics are resistant to the effects of electromagnetic interference.

By means of appropriate protective switchings there are reverse polarity protection, over-voltage resistance and a limit on power loss in the event of an error.

Pressure is captured by a zero-point measurement cell which is stable in the long term.

The hermetically-welded stainless steel membrane is vacuum-tight and has extreme burst strength.

The standardised G1/4 BSPP corrosion-resistant stainless steel connecting thread, in so far as it is compatible with stainless steel, guarantees wide-ranging media resistance.

Applications

This sensor is eminently suitable for permanent series usage, thanks to its long durability, high accuracy, high reliability and rugged stainless steel construction.

Safety advice

Please bear in mind the appropriate national safety directives (eg. VDE 0100) when installing, commissioning and running these pressure sensors.

SCP EX	1,0	1,6	2,5	004	006	010	016	025	040
pressure range * P_n (bar)	0...1,0	0...1,6	0...2,5	0...4	0...6	0...10	0...16	0...25	0...40
overload pressure P_o (bar)	1,5 times								
burst pressure P_{burst} (bar)	3 times								

SCP EX	060	100	160	250	400	600	1.000	1.600	2.000
pressure range * P_n (bar)	0...60	0...100	0...160	0...250	0...400	0...600	0...1000	0...1600	0...2000
overload pressure P_{max} (bar)	1,5 times					1,2 times			
burst pressure P_{Burst} (bar)	3 times					1,5 times			

Pressure connection	
process connection	G1/4A BSPP DIN 3852 T11, form E ED-seal FKM
Material	
parts in contact with media	CrNiCuNb 17-4 PH stainless steel; FKM
housing	X5CrNi18-10
protection class	IP67 DIN EN 60529
Plug-in connector	
4-pole; DIN EN 175301-803 form A; IP65	
Accuracy	
characteristic curve deviation	max. \pm 0,5 % FS
EX approval	
ignition protection class	II 2G EEx ia IIC T4 (IBExU06ATEX 1045)
basic standard	EN 50014; EN 50020
maximum supply	30 V; 50 mA; 1 W
temperature class	T4 (environmental -40...+85 °C)
General	
response time	\leq 1 ms
long-term stability	< 0,2 % FS/a
weight	90 g
load reversals	\leq 20 Mio.

Environmental conditions	
environmental temperature range	-40...+85 °C
compensated range	-40...+85 °C
storage temperature	-40...+125 °C
vibration resistance	20 g to IEC 60068-2-6 and IEC 60068-2-36
temperature coefficient	$\leq \pm$ 0,2 % FS/10 K
shock resistance	IEC 60068-2-32 1 m (free fall onto steel plate)
EM compatibility	
interference emissions	< 30 dB μ V/m DIN EN 61000-6-3
interference resistance	25 V/m DIN EN 61000-6-2
Power supply with EX approval	
output voltage	max. 24 VDC
output current	max. 50 mA
Ri (at 24 V)	510 Ω
output signal	4...20 mA (2-wire)

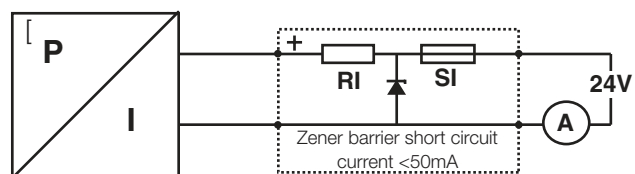

* see page 82, 6.3

SCP-EX

DIN EN 175301-803 form A

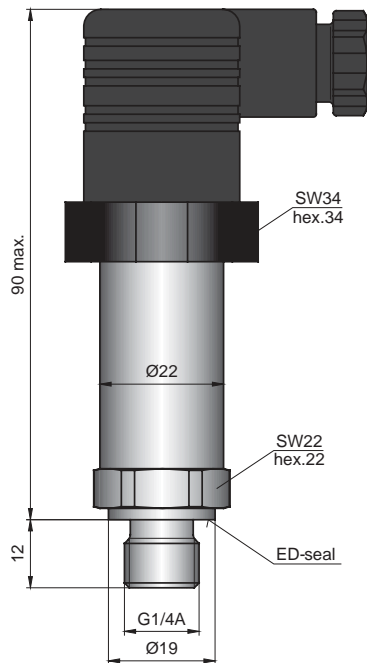
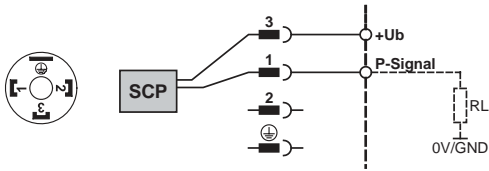

Order codes

Pressure range *

- 0.6/1.6/2.5
- 004/006/010/016/025
- 040/060/100/160/250
- 400/600/1000/1600/2000 bar

**DIN EN 175301-803 Form A,
G1/4 BSPP**

4...20 mA; 2-wire

SCP-xxx-34-06-EX

* see page 82, 6.3

1.3 SCP-MO Pressure sensors

- ✓ Compact construction
- ✓ Stainless steel cell
- ✓ Load dump protection
- ✓ High burst pressure
- ✓ Pressure peak damping
- ✓ Shock and vibration-proof
- ✓ Vibration 50 g
- ✓ IP 65 high protection class
- ✓ High over-voltage protection
- ✓ High reverse polarity protection
- ✓ EMC up to 300 V/m



The SCP-Mobil was specially developed for mobile hydraulic applications and may be modified to suit special customer requirements.

- ✓ Special electrical connections
- ✓ Special output signals
- ✓ Special protection measures
- ✓ Measurement range -1...+1 bar
up to 0...4000 bar

With its rugged and compact construction the hermetically-welded stainless steel membrane guarantees high long-term stability and freedom from leaks. The pressure cell is completely vacuum-tight, extremely resistant to bursting and accommodates all the standard media used in motor vehicles, mobile hydraulics and testing technologies. Thanks to its mechanical construction, a high degree of accuracy and long-term stability are guaranteed.

(On request a test certificate to DIN ISO 9001:2000 will be supplied)

Typical application fields

- ✓ Mobile hydraulics
- ✓ Industrial trucks
- ✓ Materials handling trucks
- ✓ Commercial vehicles
- ✓ Vehicle technology
- ✓ Braking systems
- ✓ Oil pressure
- ✓ Test equipment and technology
- ✓ Transmission control

Special electrical connections for mobile hydraulics

- ✓ Fixed cable connection
- ✓ AMP plug
- ✓ Deutsch plug with cable
- ✓ Packard plug
- ✓ MQS plug

Special output signals for mobile hydraulics

- ✓ 4...20 mA
- ✓ 0...5 V
- ✓ 1...6 V
- ✓ 0...10 V
- ✓ 0,5...4,5 V ratiometric
- ✓ PWM (variable frequencies)

Special protection measures for mobile hydraulics

- ✓ Pressure peak damping
- ✓ Load dump protection
- ✓ High over-voltage protection
- ✓ High reverse polarity protection
- ✓ EMC compatibility up to 300 V/m

The following apply to all versions:

- ✓ Measurement range from -1...+1 bar up to 0...4000 bar
- ✓ Resistant to pressure peaks (incl. protection by erosion bore)
- ✓ Welded hermetically tight, i.e. wide media compatibility
- ✓ Shock and vibration resistant (50...1000 g depending on plug)

Pressure element	
welded hermetically tight	
stainless steel membrane (without oil covering)	
thin film technology (poly-Si on SiO2)	
measurement range:	-1...+1 bar and 0...4.000 bar
pressure connection:	G1/4 BSPP Form E/HEX 22
response time:	< 1 ms
pressure cycle resistance	> 10 mio. cycles
Total error	
mixed signal ASIC for signal processing	
at 20 °C	typically ± 0,5 % FS
at -20 °C to +100 °C	typically < ± 1,5 % FS
Temperature range	
usage temperature (according to type)	-40 °C to +110 °C max. up to +140 °C
medium	up to +125 °C
Environmental conditions	
protection class	IP 65 to DIN EN 60529 up to IP 69 K
EMC	up to 300 V/m
vibration	50 g
Housing	
length (according to variant)	27, 35 and 40 mm
∅	22 mm
weight	90 g
dimensional drawing	similar to SCP-Mini

Order codes

SCP Mobil

SCP-xxx-x4-0x-MO

Pressure range *

004; 006; 010; 016;
025; 040; 060; 100;
160; 250; 400; 600;
1600; 2500; 4000 bar

Output signal

3 4...20 mA; 2-core
4 0...10 V
A 0...5 V
B 1...6 V
R 0,5...4,5 V (ratio)
P PWM

Process connection

4 G1/4 BSPP
others on request

Electrical connection

0 fixed cable
7 M12x1; 4-pole
A AMP
P Packard
D Deutsch with cable
M MQS

* see page 82, 6.3

1.4 SCT-150-14-00 Temperature sensor

- ✓ Pressure-proof up to 630 bar
- ✓ Compact construction
- ✓ Rugged steel housing
- ✓ Simple installation
- ✓ -50 °C to +125 °C
- ✓ 0/4...20 mA



Compact construction and high pressure resistance are the main features of the SCT temperature sensor.

The SCT comes into its own if temperatures at higher pressures are to be measured and a compact construction is required.

With its pressure resistance up to 630 bar, the SCT temperature sensor is very suitable for hydraulic application requirements.

It has the ability to make precise, rapid temperature measurements.

SCT series temperature sensors are compatible with the SCE built-in measuring instruments. With the latter, besides the hydraulic pressure, the temperature of the medium too can be measured, controlled and evaluated.



Input	
measurement element	silicon chip
measurement range	-25...+125 °C
measurement medium	fluid media (oil); no aggressive media
accuracy	< ± 2% FS (in built-in condition)
response time	$\tau_{0,9} = 13,5$
Output	
output _T	0...20 mA = -50...+125 °C 4...20 mA = -15...+125 °C
working resistance	≤ 250 Ω
Pressure connection	
screw-in stud	M10x1
sealing	O-ring 7,65x1,78 FKM
housing	steel C15K galvanised
working pressure P _n	630 bar

Environmental conditions	
voltage supply U _b	+11...+30 VDC
current consumption	< 30 mA
environmental temperature range	-20...+70 °C
fluid temperature range	-25...+125 °C
storage temperature	-25...+80 °C
electrical connection	fixed cable; length 3 m; open cable end; 3x0,14 mm ² screened
protection class	IP 65 DIN EN 60529

Connection designation

bn = brown
ws = white
sw = black

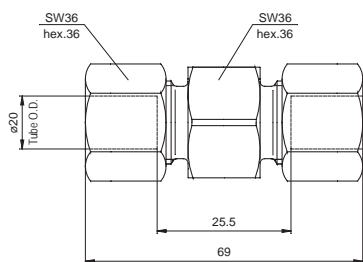
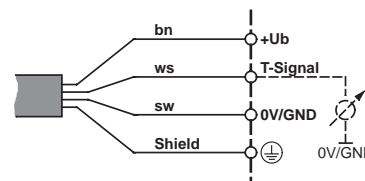

Dimension diagram SCA-GMA3/20S/T

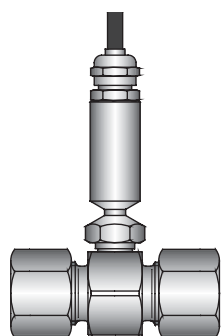

SCT-150 witt SCA-GMA

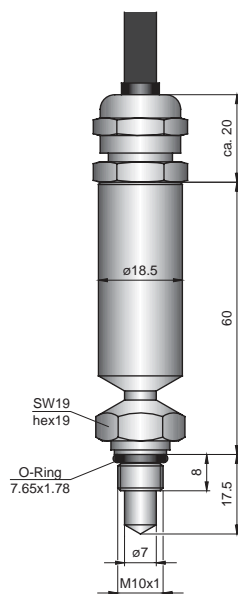

Dimension diagram SCT-150-14-00

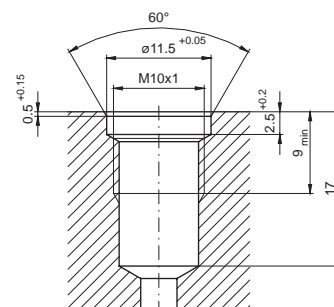

Screw-in hole M10x1/OR

Order codes

Screw-in probe with fixed cable connection (cable length 3 m)

SCT-150-14-00

In-line tube mounting adaptor

SCA-GMA3/20S/T

- ✓ Various measurement processes
 - ✓ Rapid
 - ✓ Independent of viscosity
 - ✓ Free from losses
- ✓ Plenty of measurement ranges
- ✓ Analogue output signal
- ✓ M12 plug-in connection
- ✓ 24 VDC



The **SensoControl**[®] flow sensors are used for the exact determination of volume flows in hydraulic equipment (eg test and inspection stands).

The sensors deliver an output signal proportional to the volume flow for further processing in an electronic system and are compatible with the usual proven industrial standards.





- ✓ M12 plug-in connection
- ✓ 24 VDC
- ✓ 0/4...20 mA

The volume flow can be easily displayed in combination with the SCE-020 built-in measuring instrument.

To meet a multitude of application requirements there are three different measurement principles available:

- ✓ Gear counter SCVF
- ✓ Turbine SCFT
- ✓ Spring/piston SCQ

Volume flow sensors are used in control, regulation and monitoring systems, where analogue signals to capture volume flow are needed.

	SCQ	SCFT	SCVF
Application fields			
	<ul style="list-style-type: none"> ✓ for rapid volume flow changes ✓ measurement in both directions 	<ul style="list-style-type: none"> ✓ low loss volume flow measurement 	<ul style="list-style-type: none"> ✓ measure various media ✓ measure low volume flows (leakage measurement)
	<ul style="list-style-type: none"> ✓ response time ≤ 2 ms ✓ reverse operation ✓ wide viscosity range ✓ compact ✓ up to 420 bar 	<ul style="list-style-type: none"> ✓ response time ≤ 50 ms ✓ many measurement ranges ✓ small flow resistance ✓ up to 800 l/min ✓ up to 420 bar 	<ul style="list-style-type: none"> ✓ very wide measurement range ✓ independent of viscosity ✓ up to 400 bar
Measurement range	SCQ-060: -60 ...+ 60 l/min SCQ-150: -150...+150 l/min	1,0...15/7,5...60/7,5...150/ 15...300/25...600/25...800 l/min	0...2/0...4/0,2...15/0,4...40/0,4...60/ 0,4...80/0,6...150/1...300 l/min
Connection to medium	cartridge M24 block SCAQ-xxx	G1/2...G 1 1/4 BSPP	flange & BSPP
Measurement method	spring/piston	turbine	volume/gear counter
Accuracy	< ± 2 % FS response speed ≤ 2 ms	< ± 1 % FS response speed ≤ 50 ms	< ± 0,5 % FS response speed ≤ 400 ms
Electrical connection	M12x1; 4-pole	M12x1; 4-pole	M12x1; 4-pole
Electrical output	0...20 mA = -60 ...+ 60 l/min 0...20 mA = -150...+150 l/min	4...20 mA; 2-core	0...20 mA
Applications	from inspection stands and general machinery construction through to hydraulic plant construction		
			
Order codes	SCQ-xxx-10-07	SCFT-xxx-32-07	SCVF-xxx-10-07
See pages	20-23	24-27	28-33

2.1 SCQ Flow meter

- ✓ **Measurement principle: spring/piston**
- ✓ **Response time ≤ 2 ms**
- ✓ **Measurement in both directions**
- ✓ **Wide viscosity range**
- ✓ **Compact construction**
- ✓ **Pressure resistant up to 420 bar**

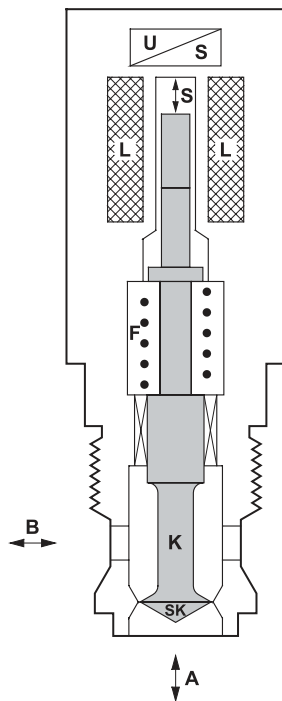

SCQ measurement principle

Function

The piston (K) is moved by flow from A to B or B to A. In idle mode, the spring (F) and piston (K) are in equilibrium. The change in travel (S) is proportional to the volume flow and is converted into a measured value by the built-in electronics. If the direction of flow changes (B to A), flow directions can be displayed (eg -45.8 l/min). The reaction time of the piston movement is smaller than 0.002 s.

Application

The rapid capture of the flow quantity is of great importance in the field of high-pressure hydraulics.

Mounting with the connection block permits a combined measurement of p, T and Q. With the in-line adaptor for tube or hose mounting, rapid installation of the SCQ into the hydraulics is achieved. The rugged construction enables use to continue even under extreme conditions, as for example, high load reversals or pressure increase speeds.

If highly dynamic volume flow changes are to be captured, the SCQ is the ideal solution. Rapid load changes, which can cause damage to valves or pumps, can be safely captured. Because of its unique measuring process, the SCQ is also in a position to capture volume flows in both directions.

	SCQ-060	SCQ-150
measurement range Q_N	-60...+60 l/min	-150...+150 l/min
Q_{max}	-66...+66 l/min	-165...+165 l/min
media connection	M24 (NG10)	M42 (NG16)
weight (g)	670	1050

Accuracy	
characteristic curve deviation	$\pm 2\%$ FS @ 46cSt.
response time	2 ms
thermal drift	$\pm 0,05\%$ FS/°C
repeat accuracy	$\pm 0,5\%$ FS
Pressure resistance	
pressure range	3...420 bar
working pressure P_N	315 bar
overload pressure P_{max}	420 bar
pressure drop ΔP (bar) @ (FS)	see diagrams
Material	
housing	steel
sealing	NBR
parts in contact with media	steel, NBR
Environmental conditions	
working temperature	+10...+60 °C
storage temperature	-20...80 °C
Tmax fluid	+80 °C
filtration	25 μ m
viscosity range	15...100 cSt.
protection class	IP67 DIN EN 60529
Electrical connections	
plug-in connector	M12x1; 4-pole
supply voltage	+18...+30 VDC
current consumption	40 mA
output	0...20 mA = -FS...+FS (10 mA = 0 l/min)
working resistance	$\leq 150\ \Omega$
signal noise	< 5 mV
EM compatibility	
interference emissions	EN 61000-6-3
interference resistance	EN 61000-6-2

Pin designation
M12 plug-in connection

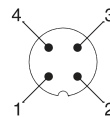

PIN	0...20 mA 3-wire
1	+U _b
2	Q signal
3	0 V/GND
4	-

SCQ-060 screw-in hole and pressure drop curve

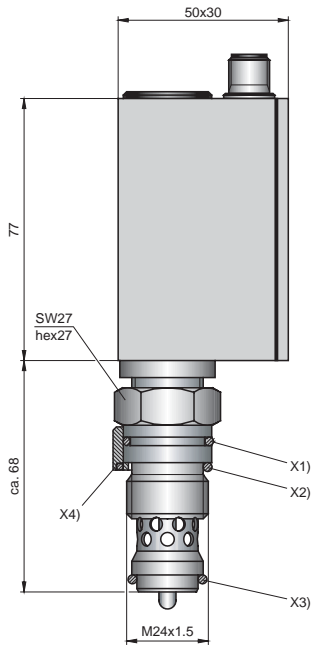

Tightening torque 20 Nm

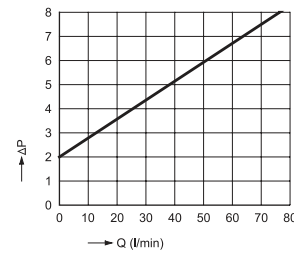
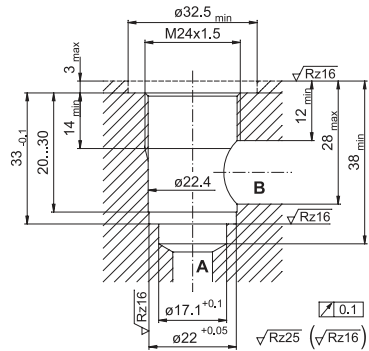

- x1) O-ring 21,95x1,78
- x2) O-ring 20,29x2,2
- x3) O-ring 15,54x2,62
- x4) C-ring

SCQ-150 screw-in hole and pressure drop curve

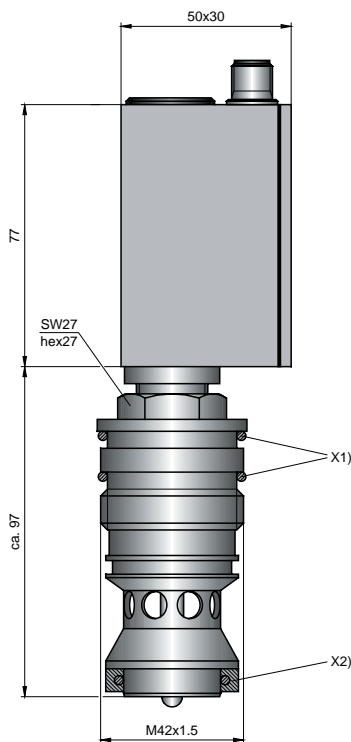

Tightening torque 30 Nm

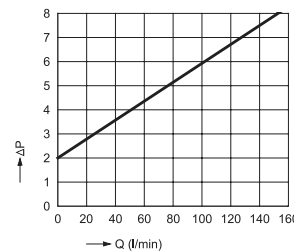
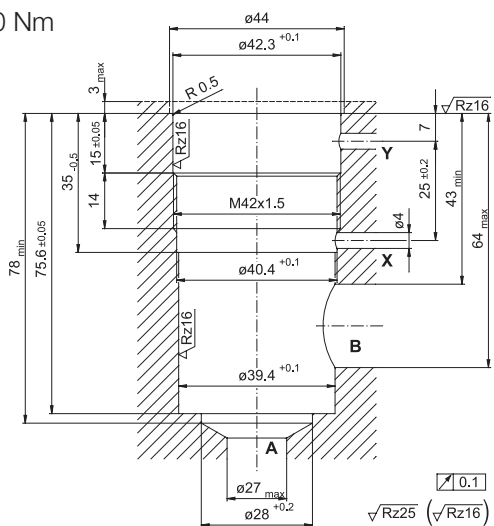

- x1) O-ring 36,17x2,62
- x2) PTFE with O-ring 2,64x2,62

SCAQ-060

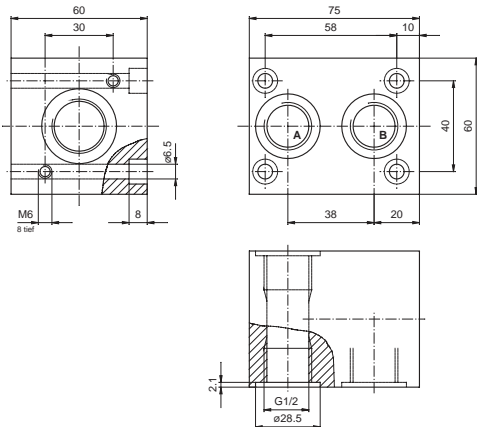

SCAQ-GI-R1/2

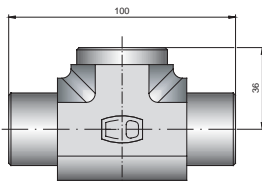

SCAQ-150

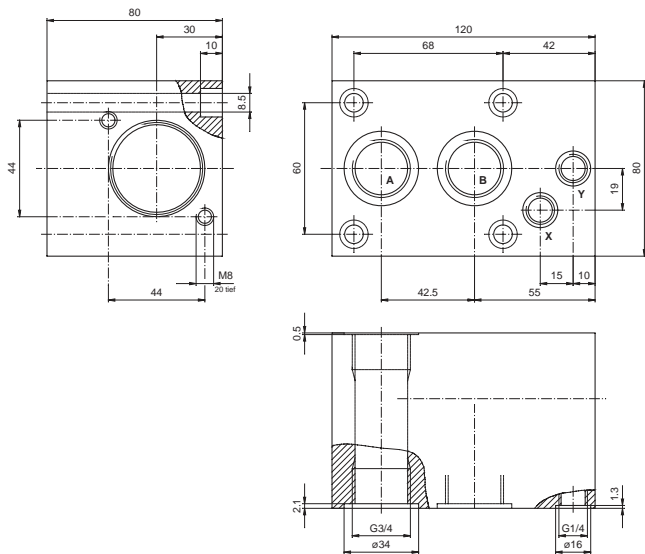

Order codes

SCQ-060 (-60...+60 l/min)

SCQ-060-10-07

M12x1, 4-pole; plug-in connector; IP67
0...20 mA; -60...+60 l/min (incl. distance ring)

SCQ-060 accessories:

in-line adaptor
G1/2 BSPP internal (A-B) und M24 internal
with locking screw:
M24 external (SCQ-M24X1,5-ED)

SCAQ-GIR1/2A4CX

connection block
G1/2 BSPP internal (A-B) and M24 internal
with locking screw:
M24 external (SCQ-M24X1,5-ED)
G1/2 BSPP external (A-B) (SCQ-R1/2-ED)

SCAQ-060

SCQ-150 (-150...+150 l/min)

SCQ-150-10-07

M12x1, 4-pole; plug-in connector; IP67
0...20 mA; -150...+150 l/min

SCQ-150 accessories:

connection block
G3/4 BSPP internal (A-B) and M24 internal
with locking screw
M42 external (SCQ-M42X1,5-ED)
G3/4 BSPP external (A-B) (SCQ-R3/4-ED)

SCAQ-150

Spare parts:

distance ring for SCQ-060
seal set for SCQ-060
seal set for SCQ-150

SC-910
SC-911
SC-912

Connecting cable and Separate plugs

connecting cable, made up

SCK-400-xx-xx

(open cable end)

cable length in m

02 2 m

05 5 m

10 10 m

plug-in connection

45 M12 cable socket; straight

55 M12 cable socket; 90° angled

Separate plugs

M12 cable socket; straight

SCK-145

M12 cable socket; 90° angled

SCK-155

2.2 Messturbine SCFT

- ✓ Measurement principle: turbine
- ✓ Response speed ≤ 50 ms
- ✓ Measurement ranges from 1 to 800 l/min
- ✓ Low flow resistance
- ✓ Nominal pressure to 480 bar
- ✓ Suitable for reverse operation
- ✓ Built-in pressure and temperature connections

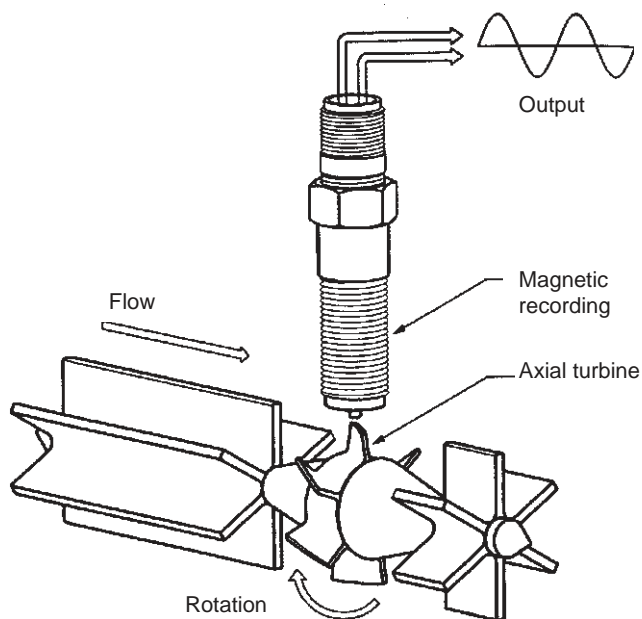

Function

The turbine wheel is driven by the oil flow and starts to turn. The frequencies which this produces are processed by the digital electronics and the influences of interfering flow effects are compensated. Thanks to low flow resistance Q_R , the hydraulic circuit is operated with low losses

Because of the special vane design, reverse operation is also possible, ie. the turbine can be operated in both directions.

The turbine is equipped with an EMA-3 screw coupling for measurement of pressure. Oil temperatures can be measured by inserting an SCT-150 directly into the turbine oil stream. In this way all the important measurement parameters are available at one installation location.

Application

If the volume flow is to be captured without loss over wide volume ranges (up to 800 l/min), then the SCFT is the ideal solution.

	SCFT-015	SCFT-060	SCFT-150	SCFT-300	SCFT-600	SCFT-800
measurement range Q_n (l/min)	1...15	4...60	6...150	10...300	20...600	25...800
accuracy (\pm %) FS/IR @ 21cSt.	± 1 % FS	± 1 % IR	± 1 % IR	± 1 % IR	± 1 % IR	± 1 % IR
working pressure P_n (bar)	420	420	420	420	350	480
connection (A - B)	G1/2 BSPP	G3/4 BSPP	G3/4 BSPP	G1 BSPP	G1 1/4 BSPP	G1 7/8 UNF
pressure drop ΔP (bar) @ (FS)	1,5	1,5	1,5	4	4	5
weight (g)	650	750	750	1200	1800	2100

FS = full scale measurement range

IR = indicated reading

response time (ms)	50
Q_{max} (l/min)	$Q_n \times 1,1$
overload pressure P_{max} (bar)	$P_n \times 1,2$
connections: temperature measurement (SCT-150) pressure (EMA-3 connection) pressure (VSTI)	M10x1 OR M16x2 G1/4 BSPP
housing	aluminium
sealing	FKM
parts in contact with media	aluminium; steel; FKM

environmental temperature (°C)	+10...+60
storage temperature (°C)	-20...+80
T_{max} fluid (°C)	+80
filtration (μ m)	25
viscosity range (cSt.)	15...100

Electrical connections	
connector	M12x1; 4-pole
supply voltage U_b	18...30 V
2-core output signal I_{out}	4...20 mA 0...FS l/min
total output current range	0-21 mA
I_B	< 30 mA

PIN designation

M12 plug-in connector

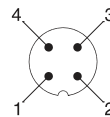

PIN	4...20 mA 2-wire
1	+ U_b
2	Q signal
3	-
4	-

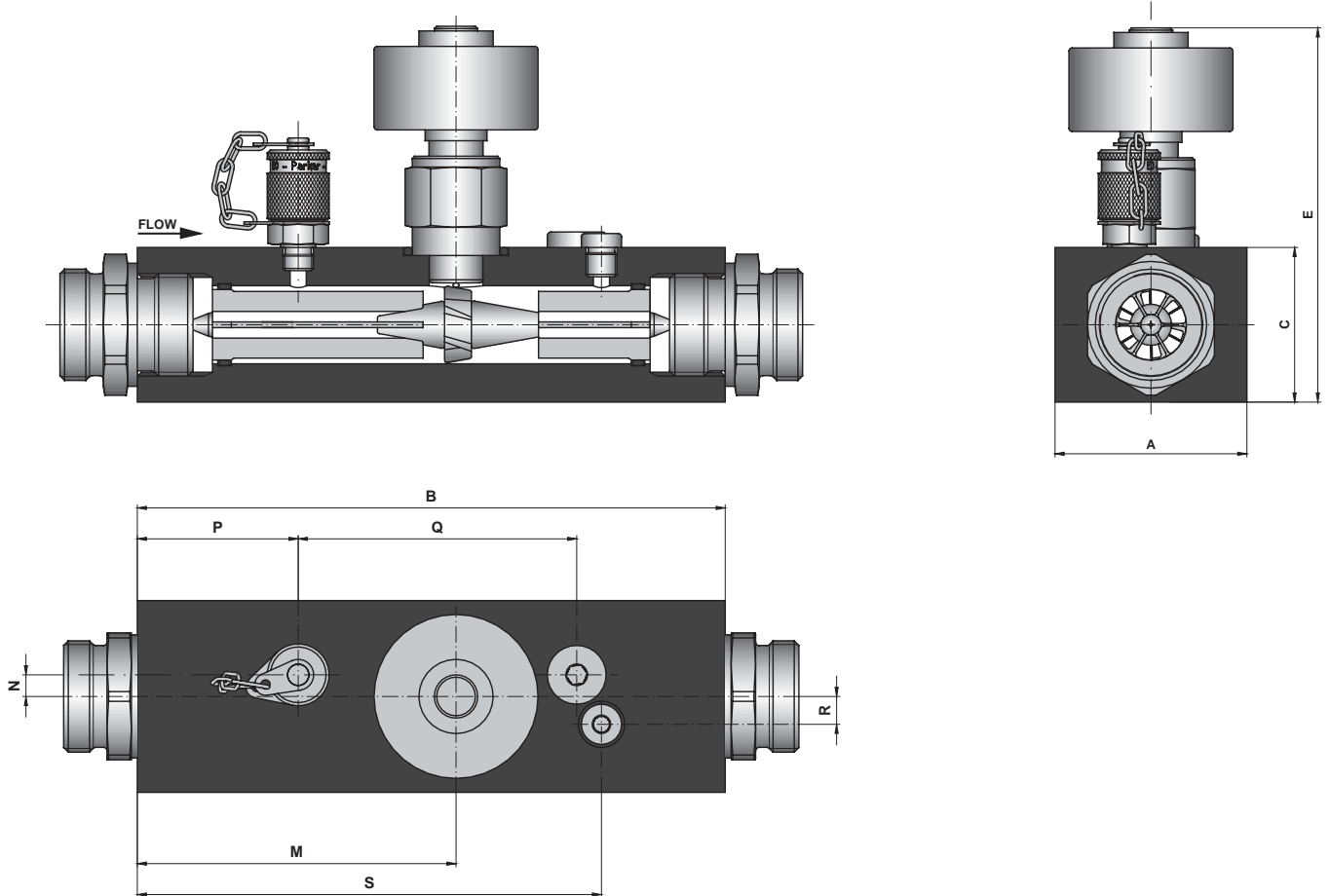

#	SCFT-015	SCFT-060	SCFT-150	SCFT-300	SCFT-600	SCFT-800
A	37	62	62	62	62	100
B	136	190	190	190	212	212
C	37	50	50	50	75	75
E	117	130	130	134	150	154
M	70	103	103	103	127	126
N	0	5	5	7	9	10
P	25	50	50	52	62	60
Q	N/A	92	92	90	106	104
R	0	5	5	9	11	10
S	115	157	157	150	168	181

Order codes**SCFT**

M12x1; 4-pole; plug-in connector; IP67

4...20 mA; 2-core

1...15 l/min	SCFT-015-32-07
4...60 l/min	SCFT-060-32-07
6...150 l/min	SCFT-150-32-07
10...300 l/min	SCFT-300-32-07
20...600 l/min	SCFT-600-32-07
25...800 l/min; P _N = 480 bar	SCFT-800-32-07

Connecting cables and separate plugs**connecting cables, made up** **SCK-400-xx-xx**

(open cable end)

cable length in m

02 2 m	_____
05 5 m	_____
10 10 m	_____

plug-in connector

45 M12 cable socket; straight	_____
55 M12 cable socket; 90° angled	_____

Separate plugsM12 cable socket; straight **SCK-145**M12 cable socket; 90° angled **SCK-155**

2.3 SCVF Volume counter

- ✓ **Measurement principle:**
gearwheel volume counter
- ✓ **8 measurement ranges**
from 0.01...2 to 1.0...300 l/min
- ✓ **Measurement accuracy $\pm 0,5$ % FS**
- ✓ **Pressure resistant to 400 bar**
- ✓ **High viscosity range**
- ✓ **Low noise**
- ✓ **Exact flow measurement**
over wide viscosity range
- ✓ **Flexible use for various media**



Gearwheel counter for high accuracy flow measurement in hydraulic equipment

Function

The **SCVF** gearwheel counter works as a volume flow counter. A very precisely machined pair of gears is driven by the fluid flow. The **SCVF** works in a wide range of viscosities. Various seals permit a variety of applications.

Applications

Thanks to this wide range of viscosities, all fluids which can be pumped and have a certain degree of lubricating ability can be measured:

- ✓ Brake fluid (EPDM seals)
- ✓ Skydrol
- ✓ Mineral oils
- ✓ Hydraulic oils
- ✓ Greases

If exact flow measurements over a wide range of viscosities are to be captured, the SCVF is the ideal solution.

SCVF	002	004	015	060	080	150	300
measurement range (l/min)	0,01...2,0	0,02...4,0	0,2...15	0,4...60	0,4...80	0,6...150	1,0...300
pressure range P_N (bar)	400	315	400	400	400	315	315
overload pressure P_o (bar)	480	400	480	480	480	350	350
connector	G3/8 BSPP	G3/8 BSPP	G3/8 BSPP	G1/2 BSPP	G1/2 BSPP	G1 BSPP	G1 BSPP
noise level db (A)	< 60	< 60	< 60	< 70	< 70	< 70	< 72
resolution (impulses/litre)	40.000	25.000	4082	965	965	333,33	191
frequency (Hz) @ FS	1333,33	1666,66	1020,5	965	1286,6	833,33	955

Accuracy	
characteristic curve deviation	± 0,5 % FS at 20 cSt.
repeat accuracy	0,01 % FS
response time *)	< 10 ms
medium **)	hydraulic oil (25 µ filter)
Material	
	1.7139 material; non-ferrous metal and silicon-free
housing	GGG 40
sealing	FKM EPDM on request
Environmental conditions	
environmental temperature	0...+55 °C
storage temperature	-25...+85 °C
fluid temperature	-30...120 °C
viscosity range	see diagram p.30
protection class	IP65 DIN EN 60529
Electrical connections	
connector	M12x1; 4-pole
supply voltage U_b	18...30 V
output signal I_{out}	0...20 mA 0...FS l/min
working resistance	< 250 Ω
current consumption I_b	< 28 mA
EM compatibility	
interference emissions	EN 61000-6-3
interference resistance	EN 61000-6-2

Pin designation
M12 plug-in connector

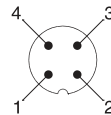

Pin	0...20 mA 3-wire
1	+ U_b
2	Q signal
3	0 V/GND
4	-

FS = full scale measurement range

*) in combination with signal converter

**) for applications with other media, please
give viscosity range and type of seals
(attach medium data sheet if applicable)

SCVF-002 Δp - Viscosity

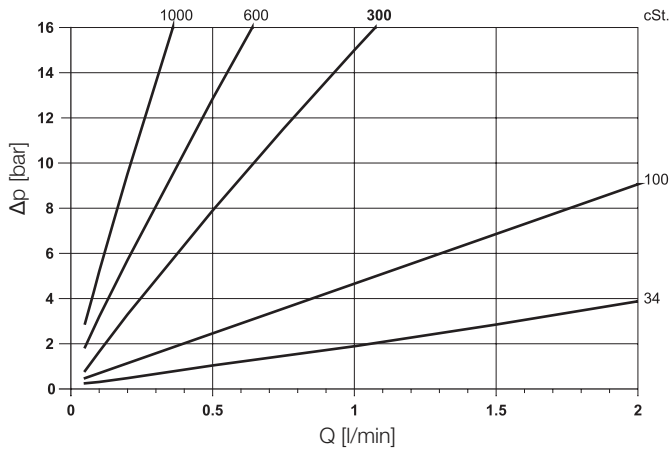

SCVF-004 Δp - Viscosity

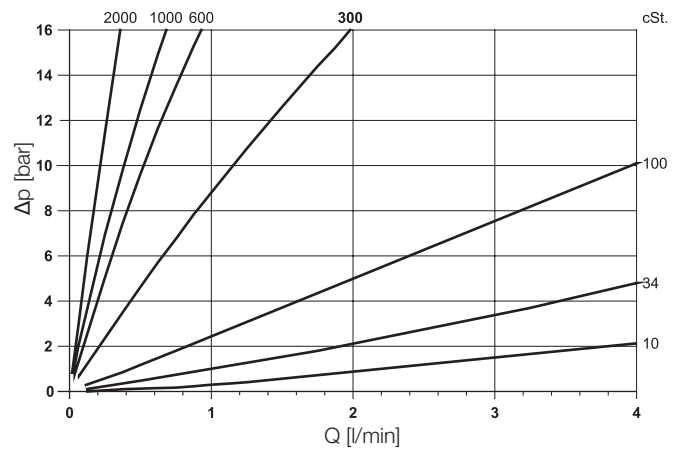

SCVF-015 Δp - Viscosity

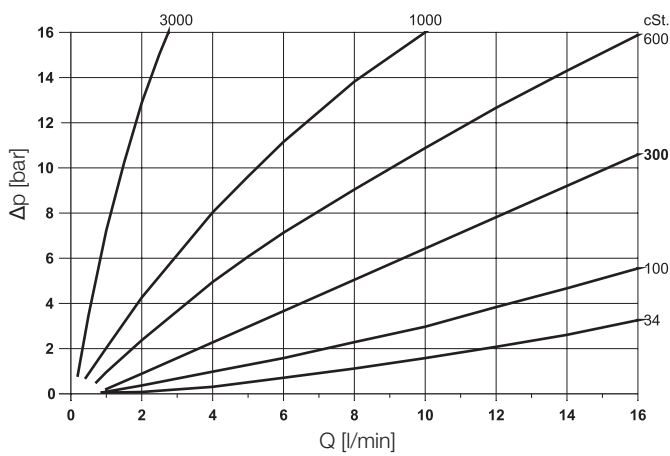

SCVF-040/060/080 Δp - Viscosity

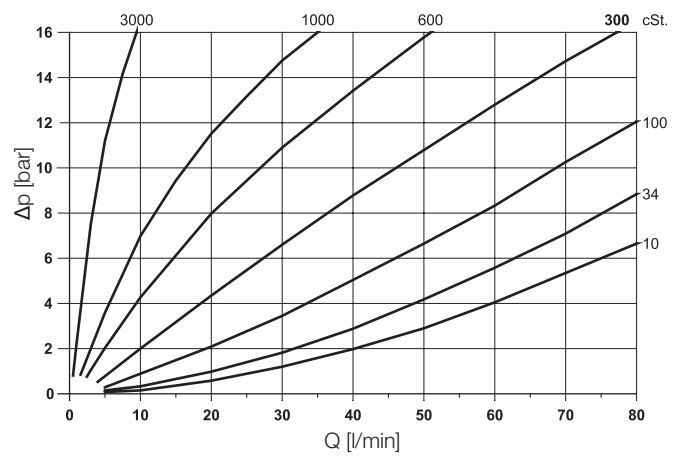

SCVF-150 Δp - Viscosity

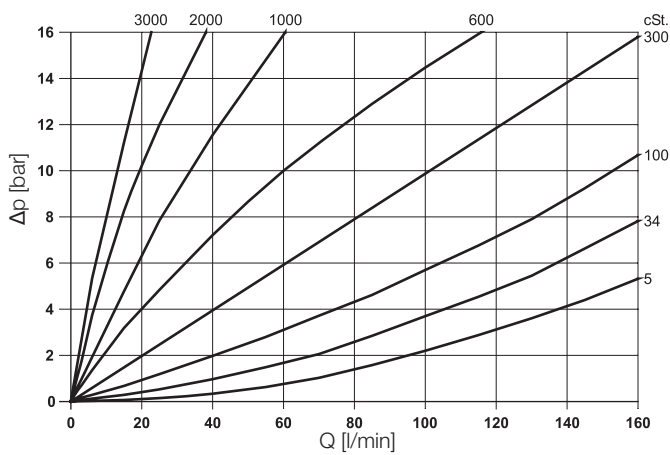

SCVF-300 Δp - Viscosity

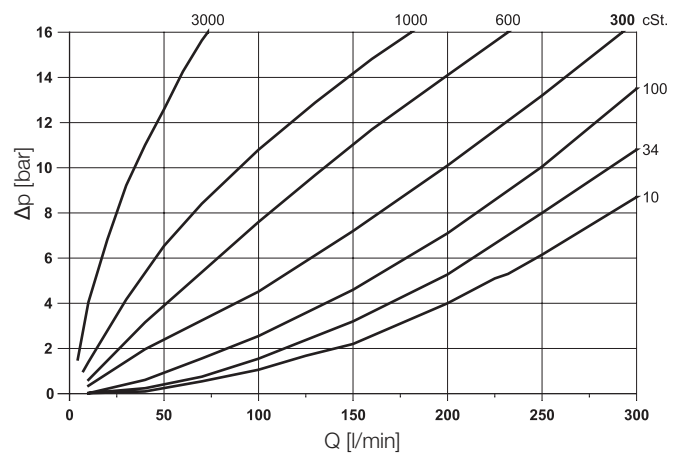

Δp = Pressure drop

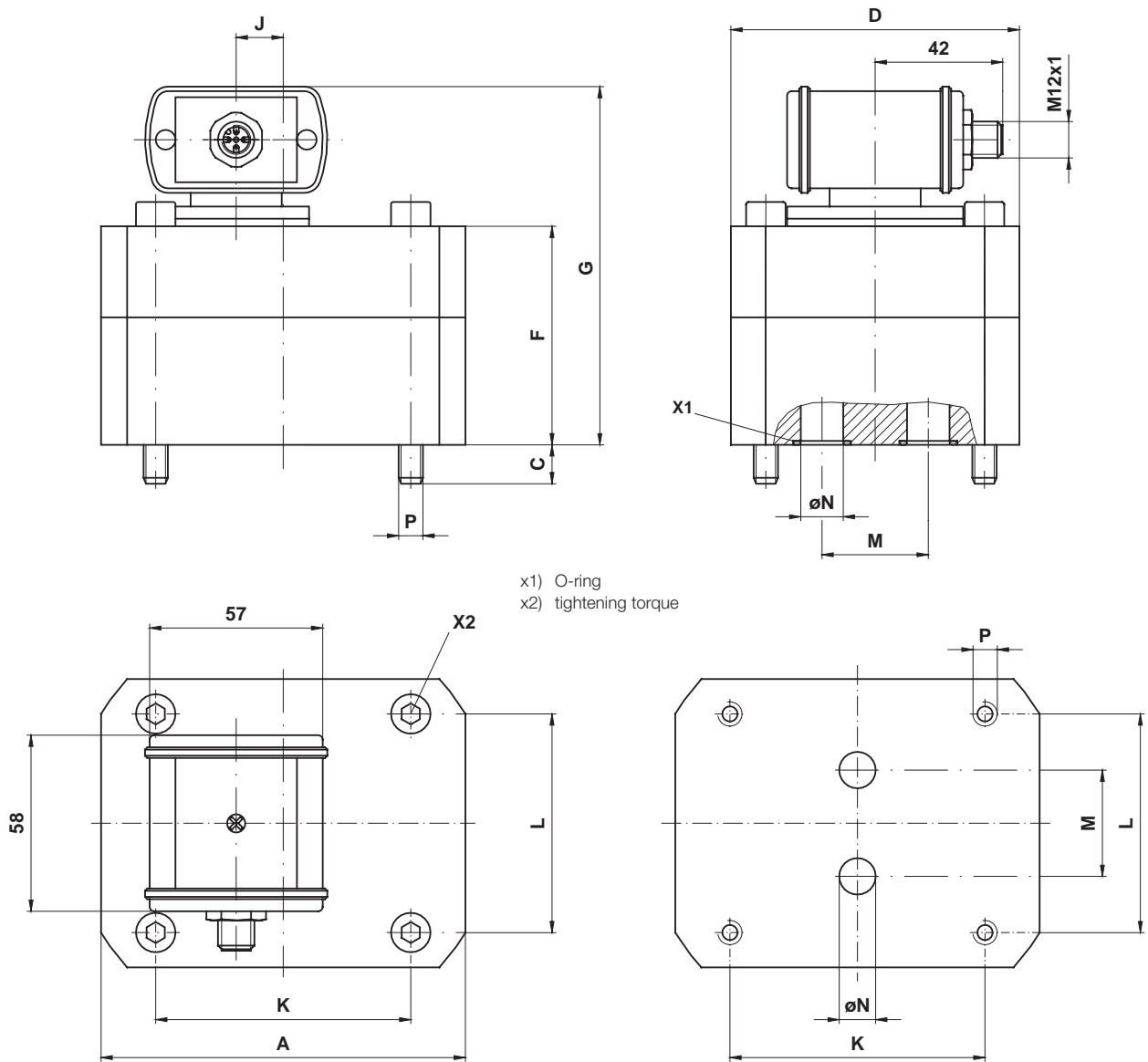

SCVF-004	2	14	85	9	60	56		-	70	40	20	6,5	M6
SCVF-015	2	14	85	13	60	57	94	-	70	40	20	9	M6
SCVF-040													
SCVF-060	5,2	35	120	13	95	72	109	10,5	84	72	35	16	M8
SCVF-080													
SCVF-150	9	120	170	18	120	89	140	46,5	46	95	50	25	M12
SCVF-300	13	120	170	22	120	105	142	40	46	95	50	25	M12

all dimensions in mm

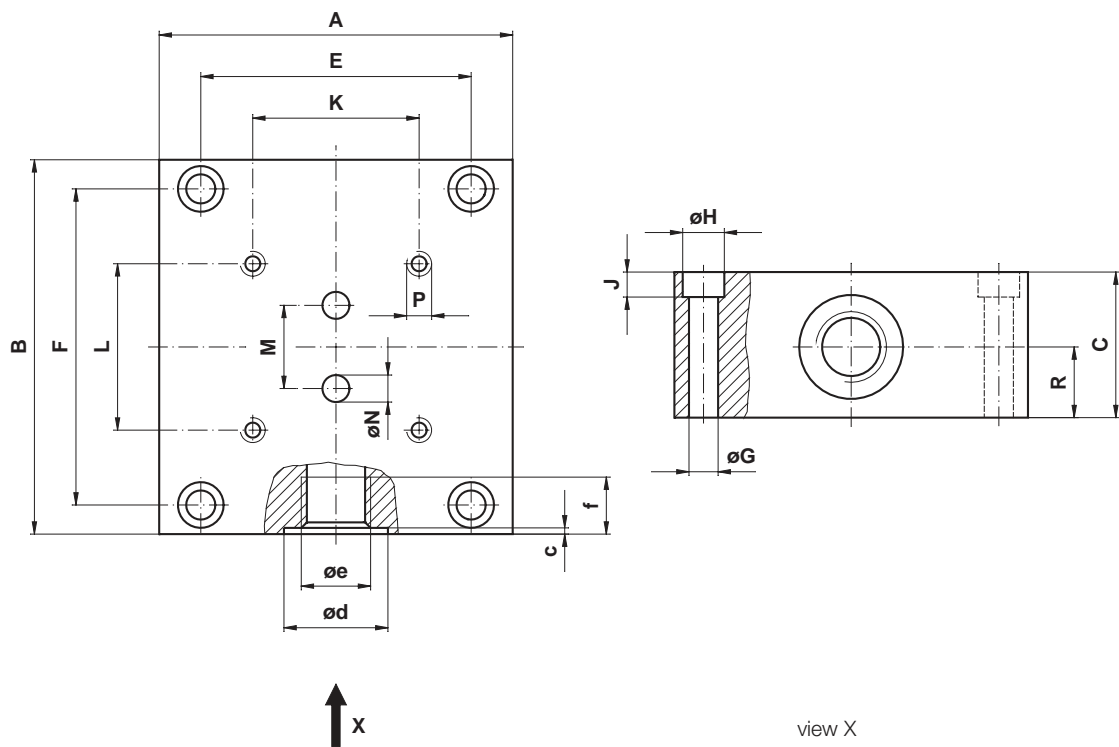

Type	kg	A	B	C	E	F	øG	øH	J	K	L	M	øN	P	R	c	ød	øe BSPP	f
SCVF-002																			
SCVF-004	1,8	85	90	35	65	76	7	11	7	70	40	20	6,5	M6/t = 14	17	0,7	25	G3/8	13
SCVF-015																			
SCVF-040																			
SCVF-060	2,9	100	120	37	80	106	7	11	7	84	72	35	12	M8/t = 18	17,5	0,7	29	G1/2	15
SCVF-080																			
SCVF-150	14	160	165	80	140	145	9	15	9	46	95	50	25	M12/t = 24	28	1	42	G1	19
SCVF-300																			

all dimensions in mm

Order codes**SCVF**

M12x1; 4-pole; plug-in connector; IP67

0...20 mA

0,01...2 l/min

SCVF-002-10-07

0,02...4 l/min

SCVF-004-10-07

0,2...15 l/min

SCVF-015-10-07

0,4...40 l/min

SCVF-040-10-07

0,4...60 l/min

SCVF-060-10-07

0,4...80 l/min

SCVF-080-10-07

0,6...150 l/min

SCVF-150-10-07

1...300 l/min

SCVF-300-10-07**Connecting cables and separate plugs****connection cable, made up****SCK-400-xx-xx**

(open cable end)

cable length in m

02 2 m**05** 5 m**10** 10 m

plug-in connector

45 M12 cable socket; straight**55** M12 cable socket; 90° angled**Separate plugs**

M12 cable socket; straight

SCK-145

M12 cable socket; 90° angled

SCK-155

- ✓ **Easily readable digital display:**
 - Large
 - Bright
- ✓ **Programmable**
- ✓ **Easily selectable units**
- ✓ **Display range can be set**
- ✓ **Input:**
 - current 0/4...20 mA
 - voltage 0...10 V
 - frequency 0...8 kHz
- ✓ **Switching output**
- ✓ **Loop-through function:**
 - analogue output
 - serial interface
- ✓ **Standard housing 96x48mm**



Plenty of connections, flexible display and copious outputs are the main features of the SCE digital display instrument.

The SCE-020 converts standard analogue signals (in the ranges 0...10 V up to 0/4...20 mA) into clearly understandable measurement values/units.

Consequently with the SCE-020, any sensor required (pressure, temperature, torque, length, etc) can be easily displayed.

Functions

The display is easily readable from a considerable distance. To show various measurement values, the desired measurement range as well as the decimal point can be freely set in a user-friendly manner.

Retained units are located on a separate luminescent surface.

Power supply can vary from 11...30 VDC.

By means of the potential-free switching output, a settable limiting value can be monitored.

Loop-through function

The analogue output or the RS232 serial interface can forward the signal to an appropriate periphery.

If various measurement values require to be shown simply and flexibly, then the SCE-020 display instrument comes to the fore.

Input	
measurement error	± 0,2 % of the display ± 1 digit
measuring rate	5 ms
	limiting value scanning every 5 ms
measurement range	freely selectable (programming)
Display	
display	4-figure 7-segment LED
display range	-999...9999
digit height	13 mm
decimal point	freely programmable
dimensions display	selectable by attaching a dimension sticker onto the luminescent surface provided
Environmental conditions	
working temperature range	0...+60 °C
storage temperature range	-25...+80 °C
relative humidity	< 80 %
protection class	IP44 nach DIN 40050
Power supply	
auxiliary energy	11...30 VDC
current consumption	approx. 100 mA
Housing	
material	PC ABS black self-extinguishing to UL94V0, for panel and console mounting
frontal dimensions	96x48 mm
mounting depth	131 mm
connector	12-pole terminal strip with wire protection, max. 1,5 mm ²
usage location	any
weight	approx. 200 g

SCE-020-2	
input	0...20 mA
	4...20 mA
	or 0...10 V
input resistance	0...20 mA = 150 Ω
	4...20 mA = 150 Ω
	0...10 V = 67 KΩ
analogue output	0...20 mA
	4...20 mA
working resistance of analogue output	≤ 500 Ω
interface	RS-232C
limiting value	potential-free normally open contact 250 V/5 A max.

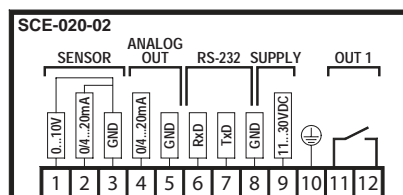

SCE-020 Connection designations

SCE-020-02
SCP Pressure sensor

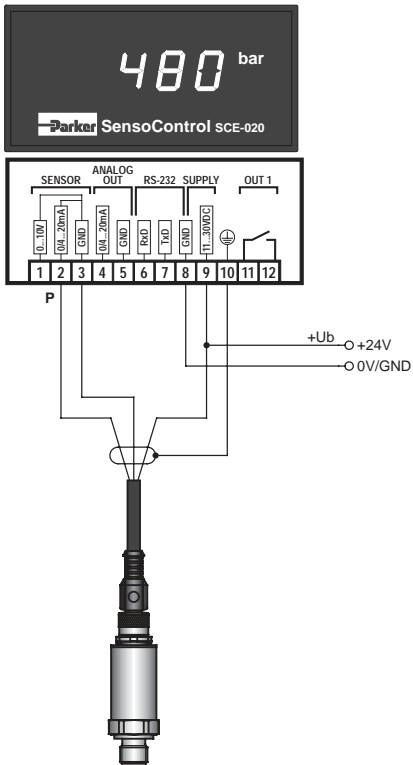

SCE-020-02
SCT Temperature sensor

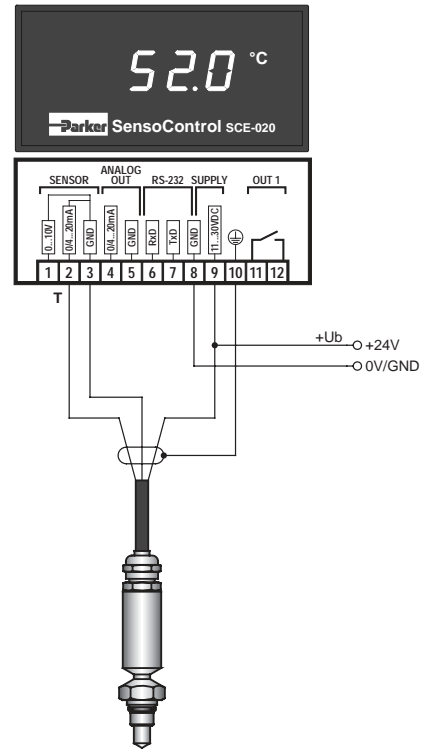

SCE-020-02
Flow rate sensor

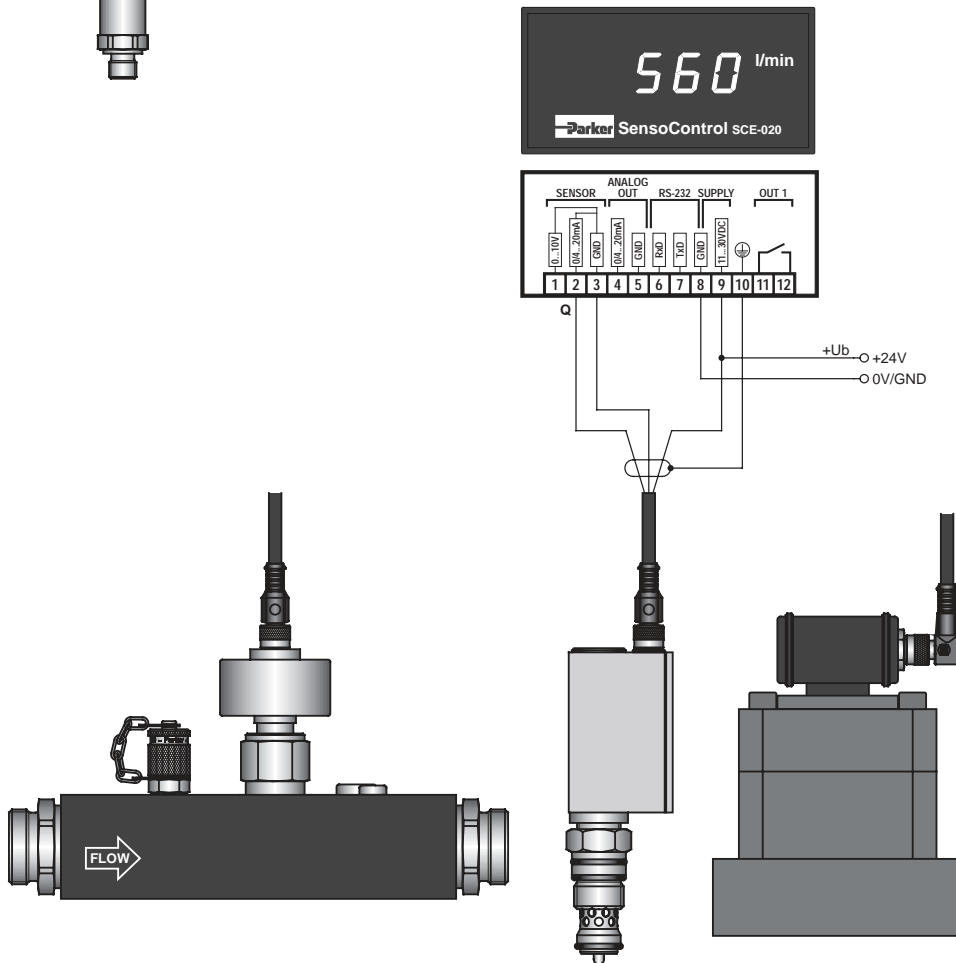

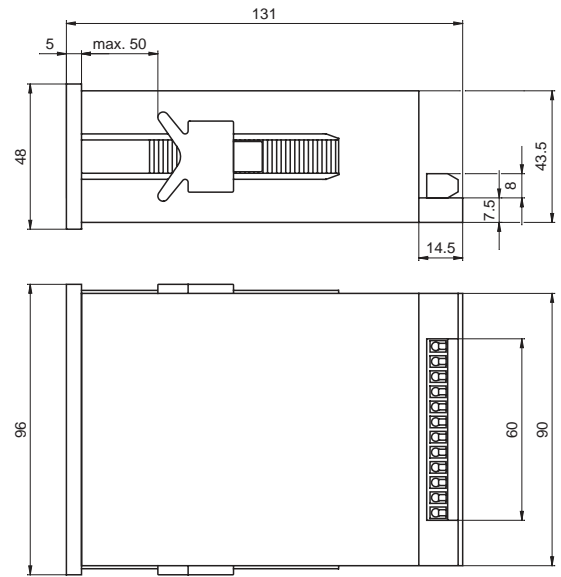
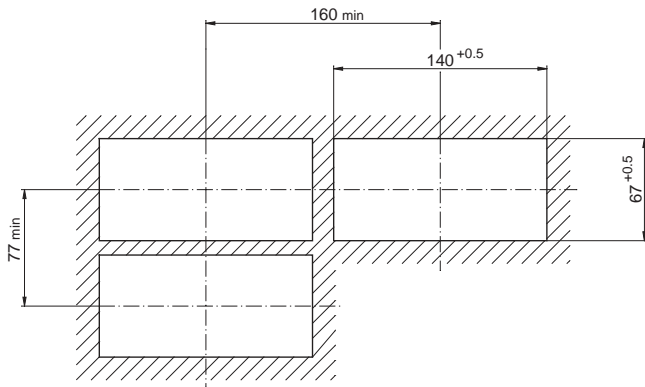

Order codes

SCE-020 input 0/4...20 mA/0...10 V

- analogue output
- + 1 switching output
- + RS232C serial interface

SCE-020-02

Accessories

- data cable SCE – PC
- power supply unit 115/230 VAC

SCK-300-02-31

SCSN-410

4. The Controller family

- ✓ Large display
- ✓ Freely settable
- ✓ Rugged metal design
- ✓ Compact
- ✓ Long-term stability
- ✓ Reliable
- ✓ Interference-proof



These Controllers are used in control, regulation and monitoring systems where switching or analogue signals, or a display, are required.

These Controllers can replace and combine all the functions of the components shown below in one instrument:

- ✓ mechanical switches
- ✓ mechanical displays
(manometers, thermometers, sight glasses)
- ✓ sensors







To make an optimal mounting location possible even in unfavourable installation conditions, all the Controller instruments have a compact and rotatable metallic housing. The large display can always be well positioned and can still be easily read even from a considerable distance.

Both the switching outputs are individually settable either as normally closed or normally open contacts and have hysteresis or window functioning. Because of this, not only the input and output switching values but also the delay times (damping) are freely selectable for the four switching points.

Intelligent settings which are not possible with a mechanical switch can be achieved with these convenient switch functions. Consequently several switches can be replaced by a single Controller.

The Controllers offer practice-oriented technical data combined with a large number of mounting and setting possibilities.

With their compact construction, long life and high functionality the Controllers stand out for lasting serial installations in hydraulic and pneumatic applications.

	PressureController	TemperatureController	LevelController	LevelTempController	OilTankController
Range of applications					
	pressure display and monitoring	temperature display and monitoring	level display and monitoring	level/temperature display and monitoring	
	<ul style="list-style-type: none"> ✓ compact ✓ resistant to pressure peaks ✓ shock and vibration-proof 	<ul style="list-style-type: none"> ✓ temperature display ✓ modular design suitable for control panel and tank construction ✓ high pressure version 	<ul style="list-style-type: none"> ✓ level display ✓ practice-oriented monitoring through window function ✓ continuous level measurement 	<ul style="list-style-type: none"> ✓ level display ✓ temperature display ✓ continuous level measurement ✓ one bore 	<ul style="list-style-type: none"> ✓ level display ✓ temperature display ✓ continuous level measurement ✓ one bore ✓ filling coupling connection ✓ Connector breath filter
Measurement range	4/10/16/60/100/250/400/600 bar	-50 °C to +150 °C -40 °C to +100 °C	250/370/520 mm	250/370/520 mm -50 °C to +150 °C	250/370/520/800/1000 mm -50 °C to +150 °C
Connection to medium	G1/4 BSPP internal/external thread	G1/2 BSPP M10x1	G1/2 BSPP	G1/2 BSPP	mounting opening to DIN 24557 part 2
Probe length	-----	100/150/250 mm	250/370/520 mm	250/370/520 mm	250/370/520/800/1000 mm
Accuracy	< ± 0,5 % FS	< ± 1 % FS	5 mm	5 mm	< 520 mm = 5 mm > 520 mm = 10 mm
Electrical connections	M12x1 DIN EN 175301-803 form A	M12x1 DIN EN 175301-803 form A	M12x1	M12x1	M12x1
Electrical outputs	<u>Version 1</u> 2 switching outputs	<u>Version 1</u> 2 switching outputs	<u>Version 1</u> 2 switching outputs	<u>Version 1</u> 2 temperature-switching outputs + 2 level-switching outputs	
	<u>Version 2</u> 1 switching output + analogue pressure signal (mA)	<u>Version 2</u> 1 switching output + analogue temperature signal (mA)	<u>Version 2</u> 1 switching output + analogue level signal (mA)	<u>Version 2</u> 1 temperature-switching output + analogue temperature signal (mA) + 1 level-switching output + analogue level signal (mA)	
	<u>Version 3</u> 2 switching outputs + analogue pressure signal (mA)	<u>Version 3</u> 2 switching outputs + analogue temperature signal (mA)	<u>Version 3</u> 2 switching outputs + analogue level signal (mA)	<u>Version 3</u> 2 temperature-switching outputs + analogue temperature signal (mA) + 2 level-switching outputs + analogue level signal (mA)	<u>Version 4</u> 2 temperature-switching outputs + 2 level-switching outputs + safety control
Application	from inspection stands to process technology, materials-handling and lifting technology and general machine construction through to pneumatic and hydraulic plant construction				
Order codes	SCPSD-xxx-x4-xx	SCTSD-150-xx-xx	SCLSD-xxx-x0-07	SCLTSD-xxx-x0-07	SCOTC-xxx-x0-07
See pages	40-45	46-57	58-63	64-69	70-75

4.1 SCPSD PressureController

- ✓ Compact
- ✓ Rugged
- ✓ Reliable
- ✓ Easy operation
- ✓ Long-term stability
- ✓ Excellent interference resistance
- ✓ Metallic housing
- ✓ High protection class
- ✓ Many variants
- ✓ Rotatable
- ✓ Analogue output
- ✓ Password
- ✓ MPa, bar, psi



The PressureController combines the functions of a pressure switch, a pressure sensor and a display instrument:

- ✓ **Pressure display (manometer)**
- ✓ **Switching outputs**
- ✓ **Analogue signal**

Simple operation, compact construction and high reliability are the most important features of the PressureController. The **PressureController** offers excellent technical data and optimal pressure management combined with many mounting possibilities. It is therefore ideal for permanent series use in industrial applications.

Easy to operate

Parameter setting is carried out via the keys or with the help of a programming module.

High functionality

Every switching output can be set individually:

- ✓ Normally closed/normally open contacts
- ✓ On and off switching pressures
- ✓ Delay times
- ✓ Hysteresis/window function
- ✓ Damping

Intelligent settings which are not possible with a mechanical switch can be achieved with these convenient switch functions. Consequently several switches can be replaced by a single Controller.

The **analogue output** is individually settable

- ✓ 0/4...20 mA switchable
- ✓ Settable initial pressure
- ✓ Settable final pressure

Reliable/safe

Pressure is captured by a measuring cell with long-term stability. Any functional error is signalled and can be further processed in accordance with DESINA. Thanks to a password, an unauthorised change of parameters can be avoided.

Rugged

The housing is made of metal and resistant to humidity, shock and vibrations. The electronics are protected from reverse polarity, overvoltage and short circuits.

Everything within view

The large illuminated display is readable even from a considerable distance. Pressures are shown in MPa, bar or psi.

Optimal installation possibilities

With its compact construction and excellent interference resistance the SCPSD is suitable for installation in critical conditions.

With its directionally settable housing, the display can always be read very easily.

Universal

Many versions are available to suit a wide variety of applications.

- ✓ Optical interface
- ✓ Switch status display

Everything in view

- ✓ Chamfered display
- ✓ Digital display
 - ✓ Large
 - ✓ Luminescent
- ✓ Display
 - ✓ psi/bar/Mpa
 - ✓ Actual pressure
 - ✓ Minimum pressure
 - ✓ Maximum pressure
 - ✓ Switching points

Easy to operate

- ✓ 3 large keys
- ✓ Display of units

Pressure connection

- ✓ Stainless steel
- ✓ Measuring cell stable long-term
- ✓ Wide media tolerance

Rugged

- ✓ Metal housing
- ✓ Watertight
- ✓ High interference resistance
- ✓ Vibration resistant
- ✓ Shockproof



Flexible installation

- ✓ Compact
- ✓ Rotatable 290°



Thread

- ✓ Internal thread
- ✓ External thread



Tube clamp

- ✓ Safe mounting with a rugged SCSD-S27 clamp

Programming module

- ✓ Can be set with ControllerWIN software

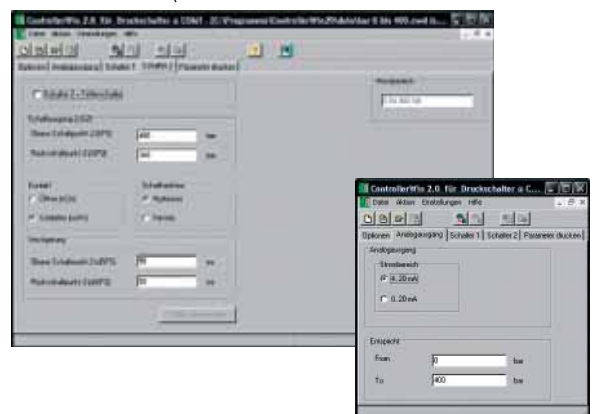

SCPSP	004	010	016	060	100	250	400	600
pressure range * P_n (bar)	-1...4	-1...10	-1...16	0...60	0...100	0...250	0...400	0...600
overload pressure P_{max} (bar)	10	20	40	120	200	500	800	1200
burst pressure P_{burst} (bar)	12	25	50	550	800	1200	1700	2200
measuring element	ceramic low pressure			DMS thin film high pressure				

Input quantities	
reversing cycles	≥ 100 Mio.
scanning rate	≥ 5 ms
connecting thread	G1/4 BSPP; ED soft seal NBR** (DIN 3852 T2, form X); ED (DIN3852 T11, form E)
torque	35 Nm
parts in contact with media	low pressure: 1.4404 stainless steel; AL2O3 ceramic; NBR high pressure: stainless steels 1.4404; 1.4542
temperature range of medium	-20 ...+85 °C
weight	approx. 300 g
Output quantities	
accuracy	± 0,5 % FS typ.; ± 1 % FS max.
temperature drift	± 0,02 % FS/°K typ. (at -20...+85 °C) ± 0,03 % FS/°K max.
long-term stability	± 0,2 % FS/a
repeat accuracy	± 0,25 % FS
switching point accuracy	± 0,5 % FS typ.; ± 1 % FS max.
display accuracy	± 0,5 % FS typ. ± 1 Digit ± 1 % FS max. ± 1 Digit
Response speed	
switching output	≤ 10 ms
analogue output	≤ 10 ms
Electrical connection	
power supply	15...30 VDC nominal 24 VDC; protection class 3
electrical connection	M12x1; 4-pole; 5-pole with gold-plated contacts. appliance inlet connector DIN EN 175301-803 form A (formerly DIN43650)
short circuit protection	yes
reverse polarity protection	yes
overload protection	yes
current consumption	< 100 mA

Housing	
	directionally adjustable up to 290°
material	pressure die-casting Z 410; painted
foil material	polyester
display	4-figure 7-segment LED; red; digit height 9 mm
protection class	IP67 DIN EN 60529; IP65 with plug-in connector DIN EN 175301-803 form A (formerly DIN43650)
Environmental conditions	
environmental temperature range	-20...+85 °C
storage temperature range	-40...+100 °C
vibration resistance	20 g; 10...500 Hz IEC60068-2-6***
shock resistance	50 g; 11 ms IEC60068-2-29***
EM compatibility	
interference emissions	EN 61000-6-3
interference resistance	EN 61000-6-2
Outputs	
switching outputs	2 MOSFET high side switches (PNP)
contact functions	normally open/normally closed; window/hysteresis; freely settable function
switching voltage	power supply - 1,5 VDC
switching current max.	0,5 A per switch
short circuit current	2,4 A per switch
analogue output	0/4...20 mA; programmable; freely scalable; RL ≤ (power supply - 8 V)/ 20 mA (≤ 500 Ω)

* see page 82, 6.3

** other sealing materials (FKM, EPDM etc.) on request

*** does not apply for DIN EN 175301-803 form A (formerly DIN43650) version

Connection designation

SCPSD-xxx-04-x6

1 switching output;
DIN EN 175301-803 form A (formerly DIN43650)

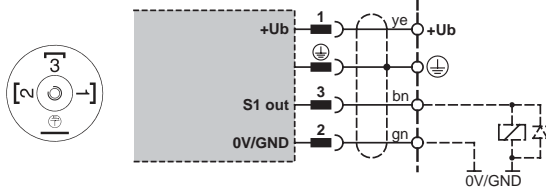

SCPSD-xxx-04-x7

2 switching outputs;
M12x1; 4-pole

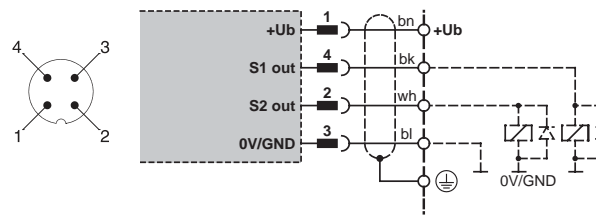

SCPSD-xxx-14-x7

1 switching output;
1 analogue output;
M12x1; 4-pole

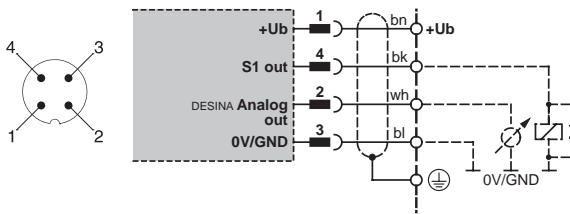

SCPSD-xxx-14-x5

2 switching outputs;
1 analogue output;
M12x1; 5-pole

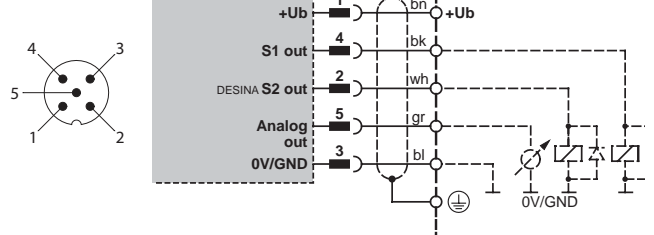

ye = yellow gn = green wh = white gr = grey
bn = brown bk = black bl = blue

Measurement range (bar)	Display resolution increment (bar)	Smallest reverse switch value RSP	Greatest switch value SP	Smallest settable difference between SP and RSP (SP-RSP)
-1...4	0,01	-1	4	0,08
-1...10	0,01	-1	10	0,05
-1...16	0,01	-1	16	0,09
0...60	0,1	0	60	0,3
0...100	0,1	0	100	0,6
0...250	1	0	250	2
0...400	1	0	400	3
0...600	1	0	600	3

Advice on selecting pressure ranges

With pressure switches the settable pressure is very relevant.

Because a 400 bar pressure switch shows the same resolution (1 bar) as a 600 bar pressure switch (also 1 bar), a 600 bar pressure switch can be deployed even at a smaller nominal pressure (eg. 315 bar).

The positive effects of this are the same accuracy with higher safety and fewer product variants.

External thread
SCPSD-xxx-x4-1x

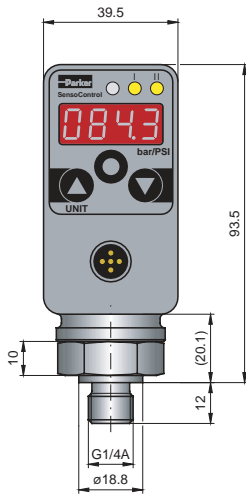

High and low pressure
DMS/ceramic

Internal thread
SCPSD-xxx-x4-2x

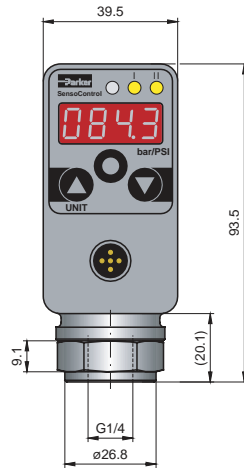

High pressure (from 60 bar)
DMS

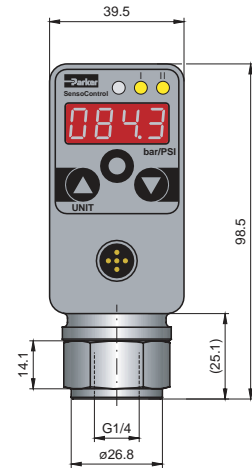

Low pressure (up to 16 bar)
Ceramic

M12 plug-in connector
SCPSD-xxx-x4-x5

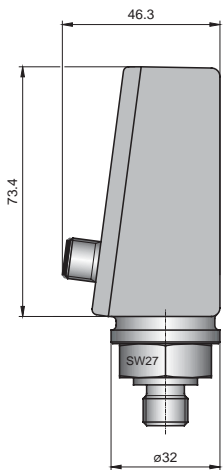

**DIN EN 175301-803 form A
(formerly DIN43650))**
SCPSD-xxx-04-x6

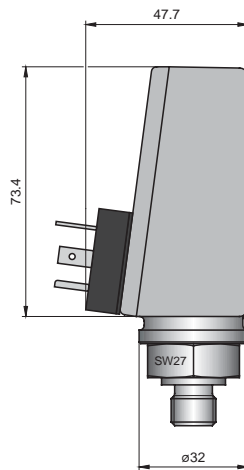

Accessories
Clamp

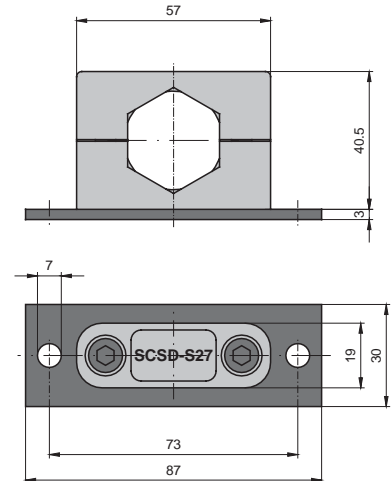

SCPSD digital pressure switch

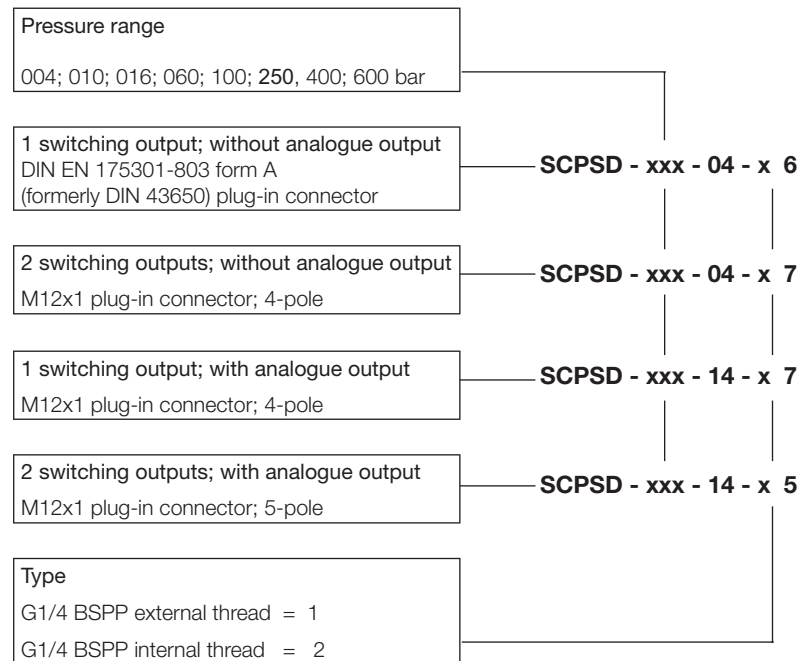

Ordering examples:

SCPSD-100-04-27
 Pressure range 100 bar
 2 switching outputs
 G1/4 BSPP internal thread
 M12 plug-in connector



SCPSD-60-14-27
 Pressure range 60 bar
 1 switching output
 1 analogue output
 G1/4 BSPP internal thread
 M12 plug-in connector



SCPSD-004-14-17
 Pressure range 4 bar
 2 switching outputs
 1 analogue output
 G1/4 BSPP external thread
 M12 plug-in connector

Accessories:

- | | |
|---|---------------------------|
| PC programming kit | SCSD-PRG-KIT |
| Fixing clamp | SCSD-S27 |
| Reducing adaptor M22x1,5 | SCA-1/4-M22x1.5-ED |
| Reducing adaptor G1/2 BSPP | SCA-1/4-ED-1/2-ED |
| Damping adaptor | SCA-1/X-EDX-1/X-D |
| Flange adaptor for mechanical pressure switch | SCAF-1/4-40 |

Connecting cable and separate plugs

Connecting cable, ready-made	SCK-400-xx-xx
(open cable end)	
Cable length in m	
02 2 m	_____
05 5 m	_____
10 10 m	_____
Plug-in connector	
45 M12 cable socket; straight	_____
55 M12 cable socket; 90° angled	_____
56 DIN EN 175301-803 form A plug connector (formerly DIN 43650)	_____

Separate plugs

- | | |
|---|----------------|
| M12 cable socket; straight | SCK-145 |
| M12 cable socket; 90° angled | SCK-155 |
| DIN EN 175301-803 Form A plug connector
(formerly DIN 43650) | SCK-006 |

4.2 SCTSD TemperatureController

- ✓ Compact
- ✓ Rugged
- ✓ Reliable
- ✓ Easy operation
- ✓ Metal housing
- ✓ High protection class
- ✓ Modular construction
- ✓ Many variants
- ✓ Rotatable
- ✓ Analogue output
- ✓ Password
- ✓ °C, °F



The TemperatureController combines the functions of a temperature switch, a temperature sensor and a display instrument:

- ✓ Temperature display (thermometer)
- ✓ Switching outputs
- ✓ Analogue signal

Simple operation, comprehensive functionality and modular construction are the most important features of the TemperatureController.

The TemperatureController offers excellent technical parameters and optimal temperature management combined with many mounting possibilities. Consequently it is ideal where temperature must be safely monitored and easily viewed.

Easy to operate

During temperature monitoring the usual matching of the limiting values (eg. cooling and alarm) is effected via the keys or a programming module.

High functionality

Every switching output can be individually set:

- ✓ Normally closed/normally open contacts
- ✓ Temperature on/off switch
- ✓ Delay times
- ✓ Hysteresis/window function

Intelligent settings can be achieved with these convenient switch functions; these would simply not be possible with a mechanical switch. Consequently several switches can be replaced by one Controller.

The analogue output is individually settable

- ✓ 0/4...20 mA switchable
- ✓ Settable starting temperature
- ✓ Settable final temperature

Reliable/safe

An existing functional error is signalled and can be processed in accordance with DESINA. Unauthorised changes to parameters can be avoided thanks to the password.

Rugged

The housing is made from metal and is protected against humidity and shock, and is resistant to vibrations. The electronics are protected against reverse polarity, overvoltage and short circuits.

Everything within view

The large luminescent display is readable even from a considerable distance. Temperatures can be shown either as °C or °F.

Temperatures can always be observed in an optimum way because of the modular construction and rotatable housing.

Optimal built-in possibilities

Different probe lengths are available for various tank sizes. These can be connected either directly or via a cable to the TemperatureController. There is also a temperature probe up to 630 bar available for high pressure applications.

Universal

There are many types available for a wide range of applications.

Application example: tank temperature monitoring

a) The equipment should shut down if the tank temperature falls below 10 °C or exceeds 60 °C.
In this regard, protection against wire breakage should be given consideration for safety reasons.

b) Cooling
If the tank temperature climbs above 50 °C, a cooler brings it down again to 40 °C.

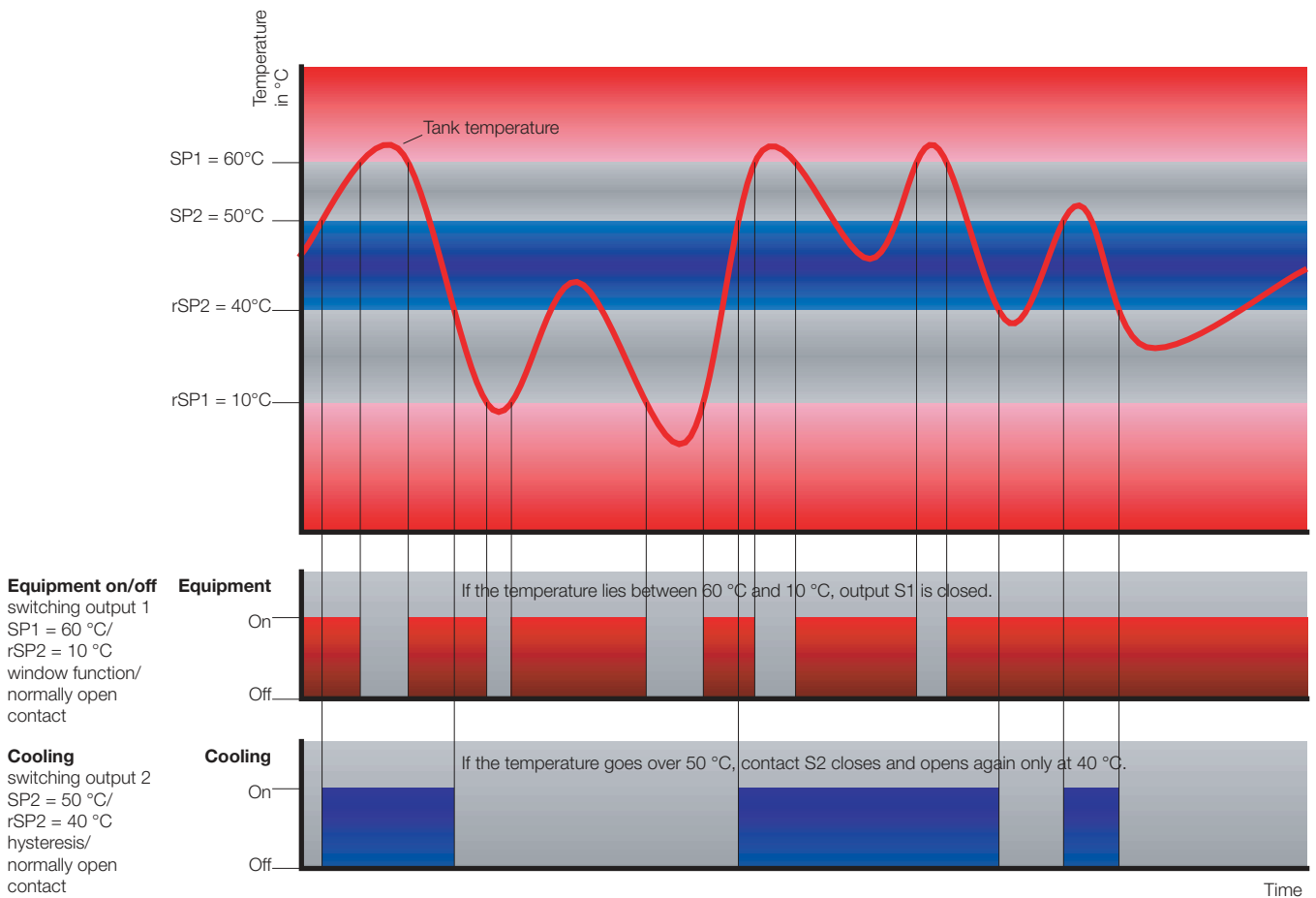

- ✓ Optical interface
- ✓ Switch status display

Everything in view

- ✓ Angled display
- ✓ Digital display
 - ✓ Large
 - ✓ Illuminated
- ✓ Display
 - ✓ °C/°F
 - ✓ Actual temperature
 - ✓ Minimum temperature
 - ✓ Maximum temperature
 - ✓ Switch points

Easy to operate

- ✓ 3 large keys
- ✓ Display of units

Connect as required

- ✓ 2 switching outputs
- ✓ Analogue output
- ✓ 0...20 or 4...20 mA
- ✓ Freely programmable
- ✓ Scalable
- ✓ Plugs
 - ✓ M12
 - ✓ DIN EN 175301-803 form A (formerly DIN43650)



Rugged

- ✓ Metal housing
- ✓ Watertight
- ✓ High interference resistance
- ✓ Vibration resistant
- ✓ Shockproof

- ✓ Can be set using ControllerWIN software

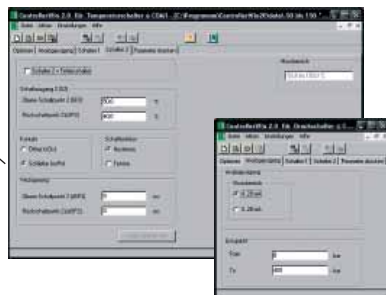

Flexible installation

- ✓ Compact
- ✓ 290° rotatable

Tube clamp SCSD-S27

Cable SCK-410-03-45-45

High pressure temperature sensor

- ✓ 630 bar
- ✓ SCTT-20-010-07

Temperature probe

- ✓ Stainless steel
- ✓ Wide media compatibility
- ✓ Various lengths
- ✓ SCTT-10-xxx-07

Height adjustable clamping fitting

- ✓ SCA-TT-10-1/2

Connection adaptor

- ✓ SCA-TT-10-SD

Immersion tube

- additional with
- ✓ higher pressures
 - ✓ aggressive media
 - ✓ SCA-TT-10-xxx immersion tube

Input quantities SCT-150	
display range	-50...+150 °C (-58...+302 °F)
Probe input	PT1000
Probe connection	M12x1; 4-pole
Output quantities	
switch point accuracy at 25 °C	± 0,35 % FS
display accuracy at 25 °C	± 0,35 % FS ± 1 digit
Electrical connection	
power supply	15...30 VDC nominal 24 VDC; protection class 3
electrical connection	M12x1; 4-pole; 5-pole; connector plug DIN EN 175301-803 form A (formerly DIN43650)
short circuit protection	yes
overload protection	yes
current consumption	< 100 mA
Housing	
	directionally adjustable up to 290°
material	zinc diecasting Z 410; painted
foil material	polyester
display	4-figure 7-segment LED; red; digit height 9 mm
connection thread	M24x1,5
protection class	IP67 EN 60529 IP 65 with appliance inlet connector* DIN EN 175301-803 form A (formerly DIN43650)

SCTT-10-xxx-07 temperature probe	
measuring element	PT1000/DIN EN 60751, class B
measurement range	-40...+125 °C; (-40...+256 °F)
response time	$\tau_{0,5} = 6 \text{ s} / \tau_{0,9} = 25 \text{ s}$
accuracy	± 0,3 K + 0,005* t
material	stainless steel 1.4571
nominal pressure (max)	10 bar
temperature of media	-40...+125 °C
environmental temperature	-25...+80 °C (for the range of plugs)
storage temperature	-25...+85 °C

* higher switch currents on request

** does not apply for DIN EN 175301-803 form A (formerly DIN43650) type

Environmental conditions	
environmental temperature range	-20...+85 °C
storage temperature range	-40...+100 °C
vibration resistance	20 g; 10...500 Hz IEC60068-2-6*
shock resistance	50 g; 11 ms IEC60068-2-29**
EM compatibility	
interference emissions	EN 61000-6-3
interference resistance	EN 61000-6-2
Outputs	
switching outputs	2 x PNP
contact functions	normally open/normally closed; window/hysteresis
switch current max.	0,7 A/switch*
response speed	300 ms
accuracy	± 1 % FS

SCTT-20-010-07 high pressure probe	
measurement element	PT1000/DIN EN 60751, class B
measurement range	-40...+125 °C; (-40...+256 °F)
usage range	fluid media, air
response time	$\tau_{0,5} = 3 \text{ s} / \tau_{0,9} = 15 \text{ s}$
accuracy	± 0,3 K + 0,005*t
material	stainless steel 1.4404
screw-in stud thread	M10x1
sealing	O-ring 7,65x1,78 mm; FKM
measurement tube diameter	7 mm
built-in length	18,5 mm
nominal pressure	630 bar
overload pressure	800 bar
burst pressure	1200 bar
media temperature	-40...+125 °C
environmental temperature	-25...+80 °C (for the range of plugs)
storage temperature	-25...+85 °C

Connection designations

SCTSD-150-00-06

1 switching output;
DIN EN 175301-803 form A (formerly DIN43650)

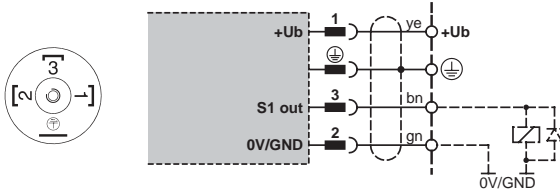

SCTSD-150-00-07
2 switching outputs;
M12x1; 4-pole

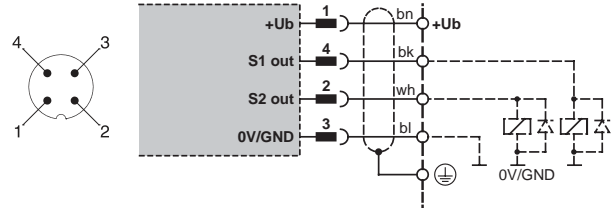

SCTSD-150-10-07
1 switching output;
1 analogue output;
M12x1; 4-pole

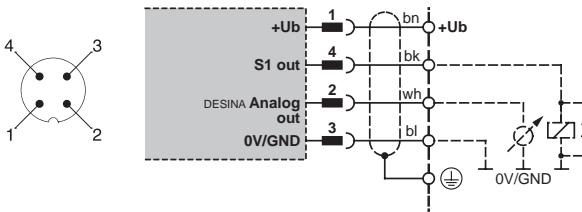

SCTSD-150-10-05
2 switching outputs;
1 analogue output;
M12x1; 5-pole

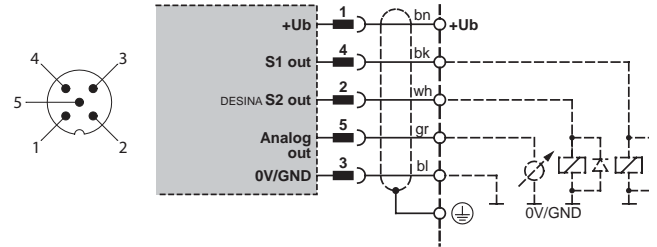

ye = yellow gn = green wh = white gr = grey
bn = brown bk = black bl =blue

Measurement range	Display resolution increment	Smallest reverse switch value RSP	Greatest switch value SP	Smallest settable difference between SP and RSP (SP-RSP)
-50 to 150 °C	0,1 °C	-50 °C	150 °C	0,8

M12 plug-in connector

SCTSD-150-x4-05

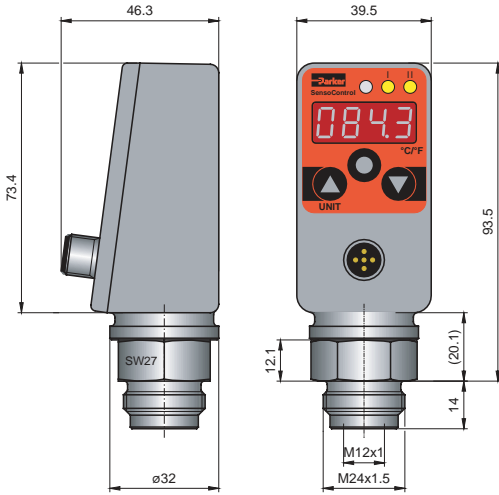

DIN 43650

SCTSD-xxx-00-06

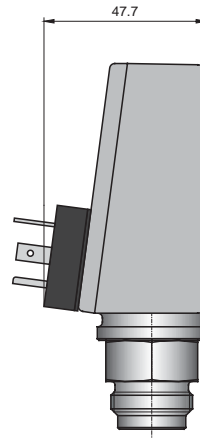

Temperature probe

SCTT-10-xxx-07

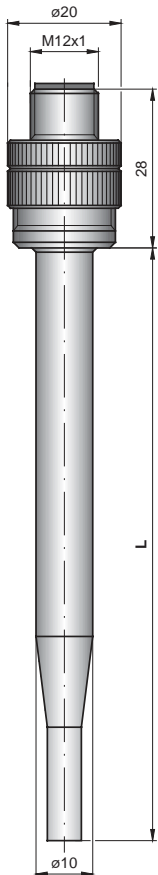

High pressure temperature probe

SCTT-20-010-07

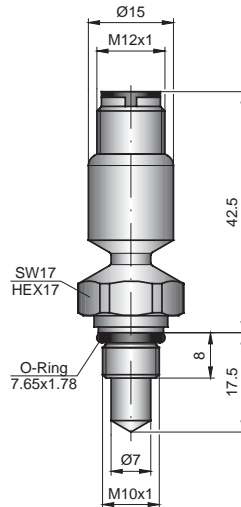

Connection designation

SCTT-x0-xxx-07

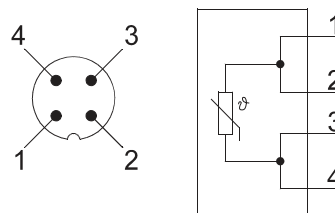

Accessory:

Connection adaptor
SCA-TT-10-SD

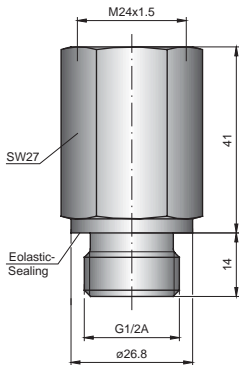

Material:

Stainless steel 1.4404

Stud adaptor:

G1/2A BSPP DIN3852-E

Seal configuration:

ED (Eolastic seal)

Stud adaptor hole:

G1/2A BSPP DIN3852-E

Spare seals:

O-ring 9,5x1,5 (FKM)
ED1/2VITX (FKM)

Accessory:

Probe cable 3 m
SCK-410-03-45-45



Accessory:

Clamping fitting
SCA-TT-10-1/2

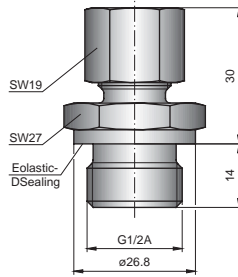

GE10LR1/2EDOMD71:

(with 10 mm bore)
1.4571 stainless steel

EO2 functional nut:

FM10L71

Stud adaptor:

G1/2A BSPP DIN3852-E

Seal configuration:

ED (Eolastic seal)

Spare seal:

ED1/2VITX (FKM)

Accessory:

SCSD-S27 clamp

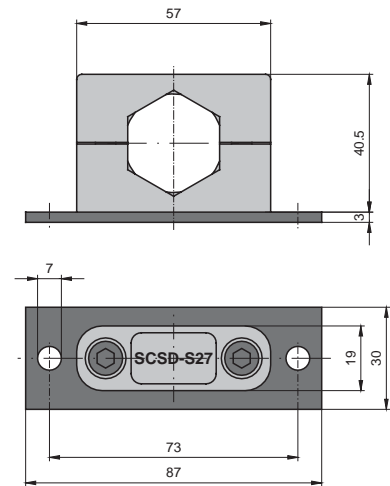

Accessory:

Immersion tube SCA-TT-10-xxx

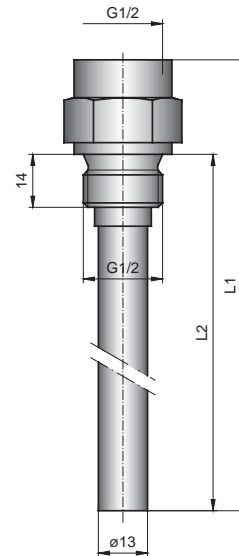

L1 = total length (mm)

L2 = built-in length (mm)

	L1	L2
SCA-TT-10-100	107	82
SCA-TT-10-150	157	139
SCA-TT-10-250	257	239

SCTSD Modular

1 switching output; without analogue output DIN EN 175301-803 form A (formerly DIN 43650) plug-in connector	SCTSD-150-00-06
2 switching outputs; without analogue output M12x1; plug-in connection; 4-pole	SCTSD-150-00-07
1 switching output; with analogue output M12x1; plug-in connection; 4-pole	SCTSD-150-10-07
2 switching outputs; with analogue output M12x1; plug-in connection; 5-pole	SCTSD-150-10-05

Components
for control console
High pressure version



fixing clamp for SCTSD	SCSD-S27
3 m probe cable (SCTSD-SCTT)	SCK-410-03-45-45
high pressure temperature probe	SCTT-20-10-07

Components
for control console



fixing clamp for SCTSD	SCSD-S27
clamping fitting G1/2 BSPP	SCA-TT-10-1/2
3 m probe cable (SCTSD-SCTT)	SCK-410-03-45-45
temperature probe	SCTT-10-xxx-07
optional: immersion tube G1/2 BSPP	SCA-TT-10-xxx
length: 100; 150; 250 mm	

Components
for direct mounting



connection adaptor (SCTSD-SCTT)	SCA-TT-10-SD
temperature probe	SCTT-10-xxx-07
optional: immersion tube G1/2 BSPP	SCA-TT-10-xxx
length: 100; 150; 250 mm	

Connecting cable & separate plugs

connecting cable, made up **SCK-400-xx-xx**
(open cable end)

Cable length in m	
02 2 m	_____
05 5 m	_____
10 10 m	_____

Plug-in connector	
45 M12 cable socket; straight	_____
55 M12 cable socket; 90° angled	_____
56 DIN EN 175301-803 form A plug connector (formerly DIN 43650)	_____

Separate plugs	
M12 cable socket; straight	SCK-145
M12 cable socket; 90° angled	SCK-155
DIN EN 175301-803 form A plug connector (formerly DIN 43650)	SCK-006

- ✓ Optical interface
- ✓ Switch status display

Everything in view

- ✓ Angled display
- ✓ Digital display
 - ✓ Large
 - ✓ Illuminated
- ✓ display
 - ✓ °C/°F
 - ✓ Actual temperature
 - ✓ Minimum temperature
 - ✓ Maximum temperature
 - ✓ Switching points

Easy to operate

- ✓ 3 large keys
- ✓ Display of units

Connect as required

- ✓ 2 switching outputs
- ✓ Analogue output
- ✓ 0...20 or 4...20 mA
- ✓ Freely programmable
- ✓ Scaleable
- ✓ M12 push-in connection

Rugged

- ✓ Metal housing
- ✓ Watertight
- ✓ High interference resistance
- ✓ Vibration resistant
- ✓ Shockproof

- ✓ Can be set with ControllerWIN software

Flexible installation

- ✓ Compact
- ✓ 290° rotatable

High pressure resistance

- ✓ to 630 bar

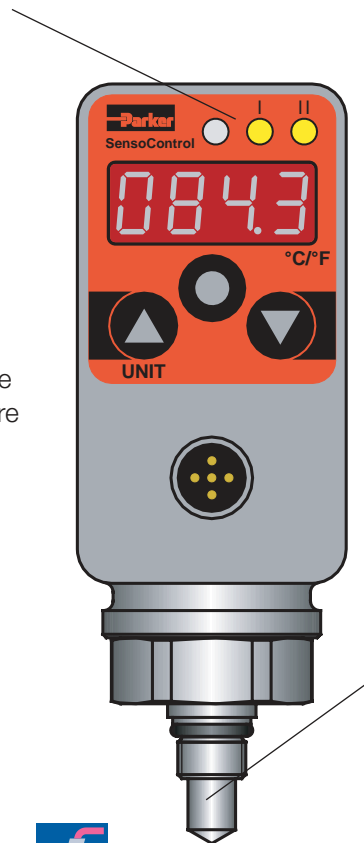

High pressure SCTSD

Input quantities SCTSD-150-x2-0x	
measurement range	-40...+100 °C
input for measuring element	PT1000/DIN EN 60751; class B
applications	fluid media; air
Output quantities	
switch point accuracy at 25 °C	± 0,35 % FS
display accuracy at 25 °C	± 0,35 % FS ± 1 digit
temperature probe	± 0,01 % FS/°C typ. (at -20...+85 °C)
long-term stability	± 0,2 % FS/a
Electrical connection	
power supply	15...30 VDC (with reverse polarity protection)
electrical connection	M12x1; 4-pole; 5-pole; with gold-plated contacts
short circuit protection	yes
overload protection	yes
current consumption	< 100 mA
Mechanical connection	
threaded screw-in stud	M10x1
sealing	O-ring 7,65x1,78 mm; FKM
measurment tube diameter	7 mm
built-in length	18,5 mm
material	1.4404 stainless steel
P _N -pressure	630 bar
P _{max}	800 bar
burst pressure	1200 bar
Housing	
	directionally adjustable to 290°
material	Z 410 zinc pressure diecasting; painted
foil material	polyester
display	4-figure 7-segment LED; red; digit height 9 mm
protection class	IP67 EN 60529

Environmental conditions	
environmental temperature range	-25...+80 °C
storage temperature range	-25...+85 °C
temperature range of medium	-40...+100 °C
vibration resistance	20 g; 10...500Hz IEC60068-2-6**
shock resistance	50 g; 11 ms IEC60068-2-29
EM compatibility	
interference emissions	EN 61000-6-3
interference resistance	EN 61000-6-2
Outputs	
switching outputs	2 x PNP
contact functions	normally open/normally closed; win- dow/hysteresis
switch current	0,5 A/switch to 85 °C; 0,7 A/switch to 70 °C
response speed	≤ 0,7 s maximum load current
Optional analogue output	
measurement range	0/4...20 mA
response speed (0-95 %)	≤ 300 ms
analogue output error	± 1 % FS
working resistance	≤ 500 Ω ab U ₀ > 18 VDC

4.2.2 SCTSD High Pressure Temperature Controller Dimensional drawing & connection

M12 plug-in connector

SCTSD-150-x4-05

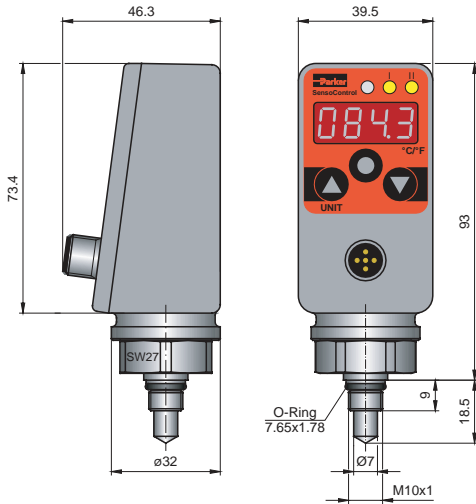

Connection designation

SCTSD-150-02-07

2 switching outputs;

M12x1; 4-pole

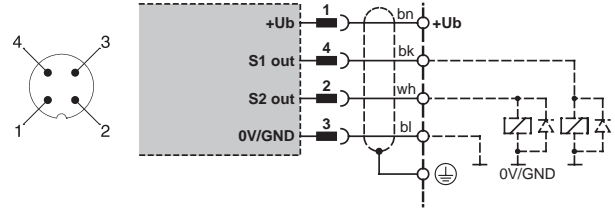

SCTSD-150-12-05

2 switching outputs;

1 analogue output;

M12x1; 5-pole

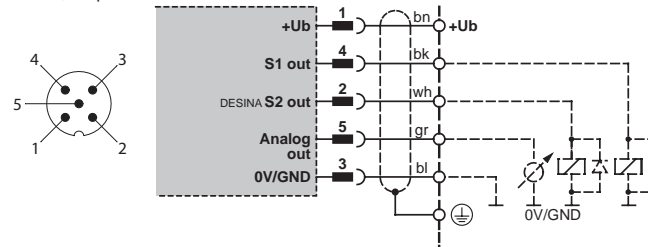

SCTSD-150-12-07

1 switching output;

1 analogue output;

M12x1; 4-pole

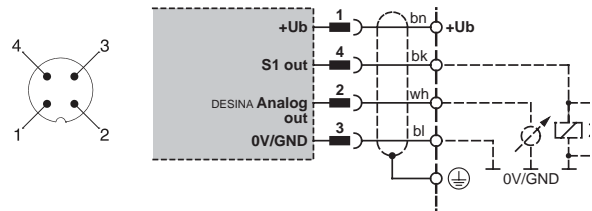

bn = brown bk = black bl = blue
gn = green wh = white gr = grey

Measurement range	Display resolution increment	Smallest reverse switch value RSP	Greatest switch value SP	Smallest settable difference between SP and RSP (SP-RSP)
-40 to 100 °C	0,1 °C	-40 °C	100 °C	0,8

High pressure SCTSD

2 switching outputs; without analogue output M12x1; plug-in connector; 4-pole	SCTSD-150-02-07
1 switching output; with analogue output M12x1; plug-in connector; 4-pole	SCTSD-150-12-07
2 switching outputs; with analogue output M12x1; plug-in connector; 5-pole	SCTSD-150-12-05
PC Programming kit	SCSD-PRG-KIT

Connecting cables & separate plugs

Connecting cables, made up (open cable end)	SCK-400-xx-xx
Cable length in m	
02 2 m	
05 5 m	
10 10 m	
Plug-in connector	
45 M12 cable socket; straight	
55 M12 cable socket; 90° angled	

Separate plugs	
M12 cable socket; straight	SCK-145
M12 cable socket; 90° angled	SCK-155

4.3 SCLSD LevelController

- ✓ Proven measurement system
- ✓ Rotatable
- ✓ Level display
- ✓ mm/inch/% display
- ✓ High & low display
- ✓ Analogue output
- ✓ Switching outputs
- ✓ No surge tube needed
- ✓ Genuine 5 mm resolution
- ✓ Replaces several mechanical switches



The LevelController combines the functions of a level switch, level sensor and level display:

- ✓ Level display (sight glass)
- ✓ Switching outputs
- ✓ Analogue signal

The **LevelController** provides the best way of monitoring tank levels.

Easy to operate

Parameter settings are made either with the keys or with a programming module.

High functionality

Every switching output can be individually set:

- ✓ Normally closed/normally open contacts
- ✓ Upper/lower switching points
- ✓ Delay times
- ✓ Hysteresis/window function
- ✓ Damping

The **analogue output** can be set individually

- ✓ 0/4...20 mA switchable
- ✓ upper level settable
- ✓ lower level settable

Reliable/safe

The float position is continually captured in fine steps (≥ 5 mm) and shown on the display in mm or inches. Because levels are registered continually, there is no longer

the danger of "sticky" individual mechanical contacts. This means that the operational safety of the installation being monitored is significantly higher. A password enables unauthorised parameter changes to be avoided.

Everything within view

The large illuminated display is readable even from a considerable distance. Because a percentage display can be selected, the levels are independent of the shape of the tank and therefore uniformly read by the operator. Also, an offset (the difference from the probe to the bottom of the tank) can be input to enable the level above the bottom of the tank to be realistically shown.

Due to the menu-selected setting of switching points for levels, the most varied of applications can be conveniently achieved, or subsequently corrected. Since switching points do not have to be quoted at the time of ordering, this reduces the usual great variety of mechanical level switches required.

Universal

In combination with convenient switch functions such as hysteresis and window, and normally closed and normally open contacts, intelligent settings can be achieved with the **LevelController**; these are not possible with a mechanical level switch. This means that several switches can be replaced by a single Controller. In addition, with the optional analogue output there is the possibility of monitoring levels more conveniently with a single control (eg. leakage monitoring).

Application example: tank monitoring

Because the conventional specifications for mechanical level switches (mm relative to the tank cover) are sometimes utilised during design, these specifications have been chosen in the following practical example.

a) If the tank level falls below 310 mm (measured from the upper edge of the tank to running dry) or exceeds the 70 mm level (measured from the upper edge of the tank to overflow), then switch-off should occur. In this instance a broken wire protector should be considered for reasons of safety.

b) Automatic tank filling
 If the tank level falls below 240 mm (measured from the upper edge of the tank), then the tank should be automatically filled by a pump up to 110 mm (measured from the upper edge of the tank).

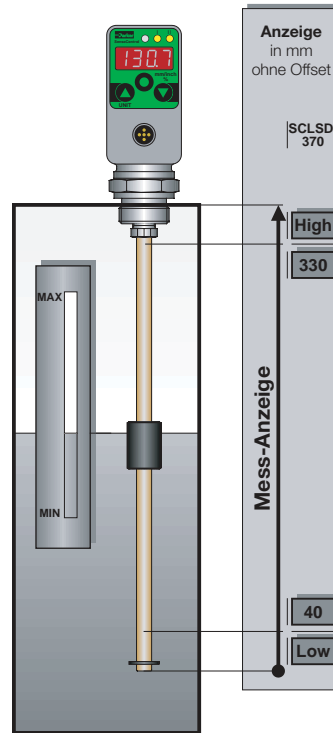

Resultant switch values for an SCLSD-370 mm

Upper stop:
 370 mm - 70 mm = 300 mm
 lower stop:
 370 mm - 310 mm = 60 mm
 window function/normally open contact.

If the level is between 300 and 60 mm output S1 is closed.

Load stop:
 370mm - 110 mm = 260 mm
 load on:
 370 mm - 240 mm = 130 mm
 Hysteresis function/
 normally closed contact

If the level falls below 130 mm, the contact closes and opens again only when 260 mm has been exceeded.

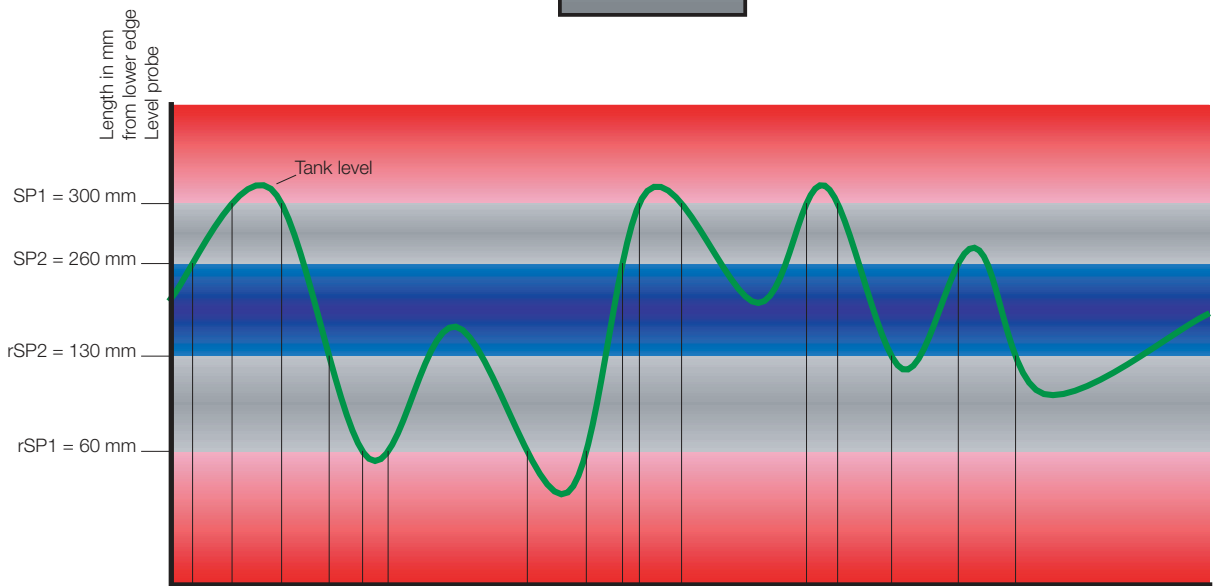

Installation on/off installation

switching output 1
 SP1 = 300 mm
 rSP1 = 60 mm
 window function/
 normally open contact

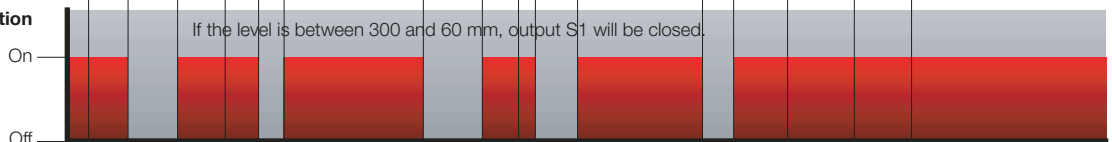

Fill tank

switching output 2
 SP2 = 260 mm
 rSP2 = 130 mm
 hysteresis/
 normally closed contact



- ✓ Optical interface
- ✓ Switch status display

Everything in view

- ✓ Angled display
- ✓ Digital display
 - ✓ Large
 - ✓ Illuminated
- ✓ Display
 - ✓ mm/inch/%
 - ✓ Actual level
 - ✓ High & low display
 - ✓ Switch points

Easy to operate

- ✓ 3 large keys
- ✓ Display of units

Connect as required

- ✓ 2 switching outputs
- ✓ Analogue output
- ✓ 0...20 or 4...20 mA
- ✓ Freely programmable
- ✓ Scaleable
- ✓ M12 plug –in connector



Rugged

- ✓ Metal housing
- ✓ Watertight
- ✓ High interference resistance
- ✓ Vibration-proof
- ✓ Shock-proof

Mount as required

- ✓ Compact
- ✓ 290° rotatable
- ✓ G3/4 BSPP
- ✓ Flange for DIN

Proven measurement system

- ✓ High float dynamics
- ✓ Small construction
- ✓ Universal applicability

No surge tube required

- ✓ Electronic damping/ damping settable

- ✓ Settable via ControllerWIN software

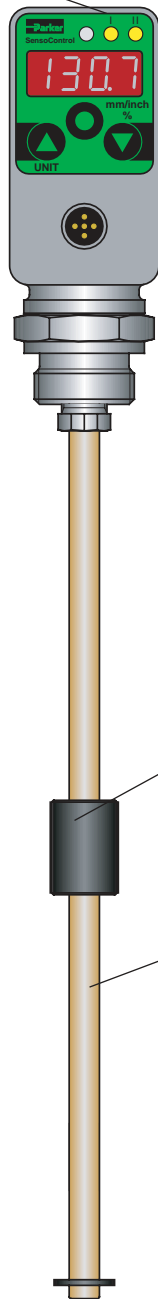

Input quantities	
measurement element	resistance reed array with float
connecting thread	G3/4 BSPP; nickel-plated brass; ED soft seal NBR*
parts in contact with medium	brass; nickel-plated brass; NBR*
temperature range of medium	-20...+85 °C
media compatibility	water; lubricating oil; hydraulic oil; acids; alkalis
Output quantities	
switching point accuracy	± 1 % FS at 25 °C
display accuracy	± 1 % FS ± 1 digit at 25 °C
response speed	≤ 700 ms
resolution	7,5 mm
Float	
material	NBR
dimensions	Ø 18 mm, Length 35 mm
Level rod	
material	brass
dimensions	Ø 8 mm
working pressure	1 bar
Electrical connection	
power supply	15...30 VDC nominal 24 VDC; protection class 3
electrical connection	M12x1; 4-pole; 5-pole; with gold-plated contacts
short circuit protection	yes
reverse polarity protection	yes
overload protection	yes
current consumption	< 100 mA

Housing	
	directionally adjustable up to 290°
material	zinc diecasting Z 410; painted
foil material	polyester
display	4-figure 7-segment LED; red; digit height 9 mm
protection class	IP67 DIN EN 60529
Environmental conditions	
environmental temperature range	-20...+85 °C
storage temperature range	-40...+100 °C
EM compatibility	
interference emissions	EN 61000-6-3
interference resistance	EN 61000-6-2
Outputs	
switching outputs	2 MOSFET high side switches (PNP)
contact functions	normally open /normally closed window/hysteresis function freely settable
switch voltage	power supply 1,5 VDC
switch current max.	0,5 A per switch
short circuit current	2,4 A per switch
analogue output	0/4...20 mA; programmable; freely scaleable RL ≤ (power supply 8 V)/ 20 mA (≤ 500Ω)

*other sealing materials (FKM, EPDM etc.) on request

Percentage display example

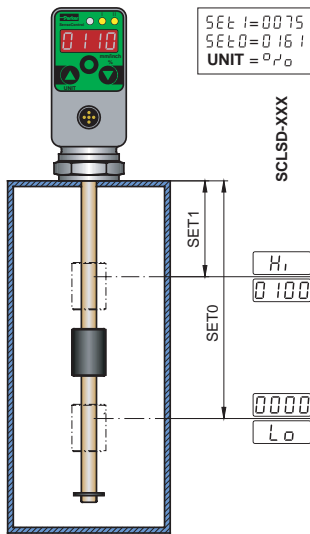

mm display example

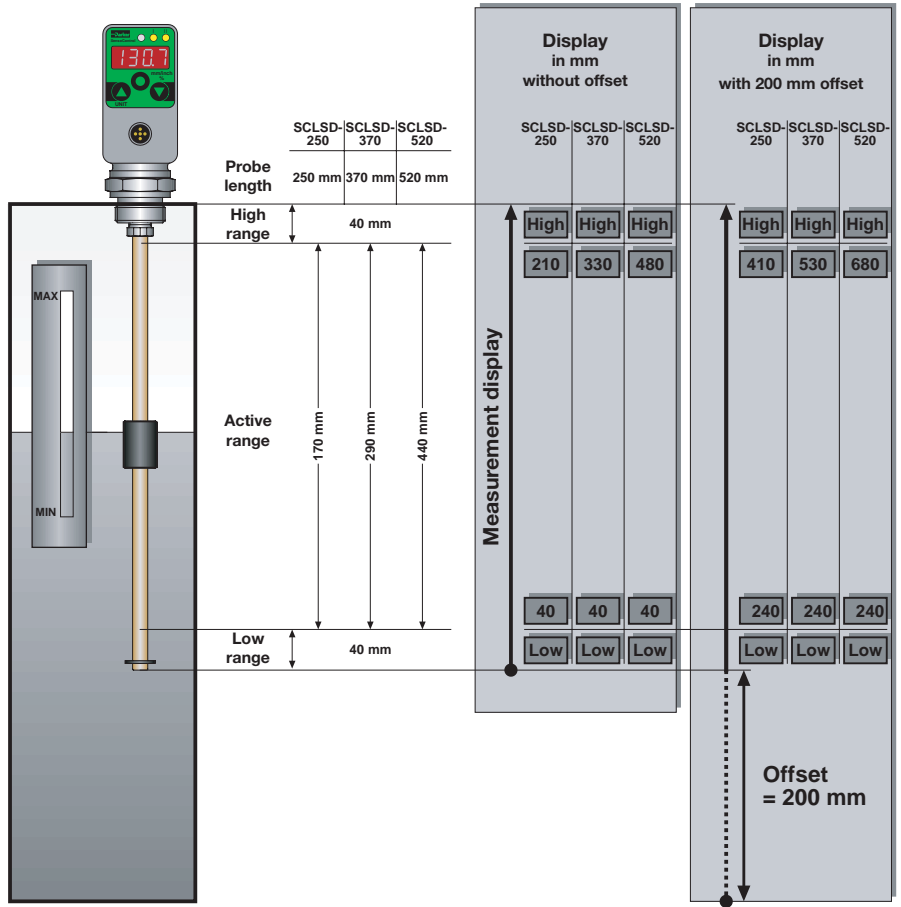

L1 Probe length measurement range	L2 Active range	Display resolution increment	Increment	Smallest reverse switch value RSP	Greatest switch value SP	Smallest settable dis- tance between SP and RSP (SP-RSP)
250 mm	40...210 mm	1 mm	5 mm	40	210	5 mm
370 mm	40...330 mm	1 mm	5 mm	40	330	5 mm
520 mm	40...480 mm	1 mm	5 mm	40	480	5 mm

Connection designation

SCLSD-xxx-00-07
2 switching outputs;
M12x1; 4-pole

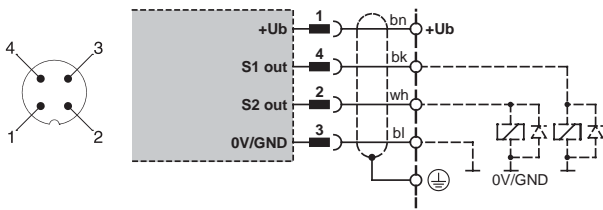

bn = brown bk = black wh = white bl = blue

SCLSD-xxx-10-07
1 Switching output;
1 analogue output;
M12x1; 4-pole

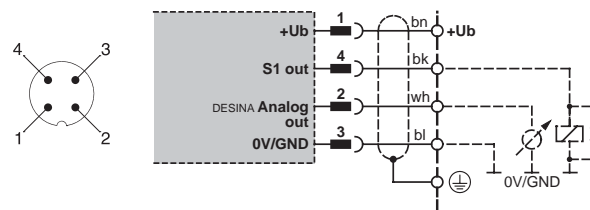

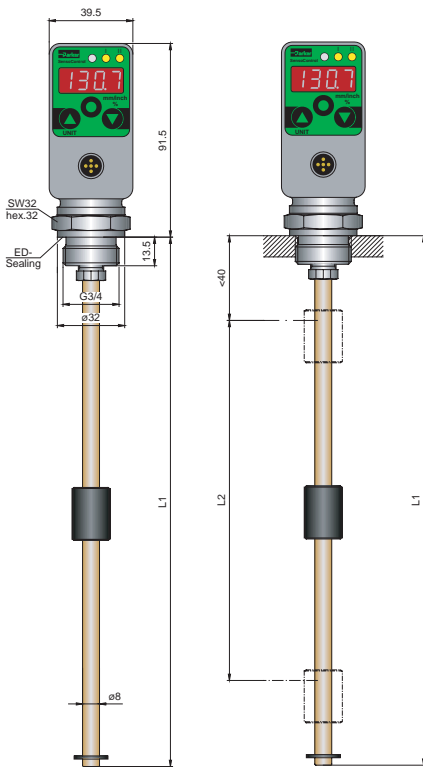

L1 = Length
L2 = Adjustable area

SCLSD LevelController

- built-in length (L1)
250/370/520 mm
- 2 switching outputs; without analogue outputs
M12x1; plug-in connector; 4-pole → **SCLSD - xxx - 00-07**
- 1 switching output; with analogue output
M12x1; plug-in connector; 4-pole → **SCLSD - xxx - 10-07**
- 2 switching outputs; with analogue output
M12x1; plug-in connection; 5-pole → **SCLSD - xxx - 10-05**

Accessory

PC Programming kit
Flange adaptor, 6-hole connection DIN 24557, part 2

SCSD-PRG-KIT
SCAF-3/4-90

Connecting cable and separate plugs

Connecting cable, made up **SCK-400-xx-xx**

(open cable end)

Cable length in m

02 2 m

05 5 m

10 10 m

Plug-in connector

45 M12 cable socket; straight

55 M12 cable socket; 90° angled

Separate plugs

M12 cable socket; straight

SCK-145

M12 M12 cable socket; 90° angled

SCK-155

SCLSD-xxx-10-05

2 switching outputs;
1 analogue output;
M12x1; 5-pole

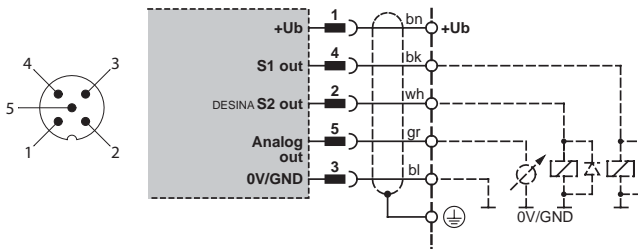

4.4 SCLTSD LevelTempController

- ✓ Proven measurement system
- ✓ Rotatable
- ✓ Level display
- ✓ mm/inch/% display
- ✓ High & low display
- ✓ Analogue output
- ✓ Switching outputs
- ✓ Only one bore
- ✓ No surge tube required
- ✓ Genuine 5 mm resolution
- ✓ Replaces several mechanical switches



With the **LevelTempController** it is now possible to set and display separately both temperature and level on a common platform. It is in tank monitoring that the integration of level and temperature opens up possibilities for you in a unique way.

The LevelTempController combines the functions of a level/temperature switch, a level/temperature sensor and a level/temperature display:

- ✓ Level/temperature display (thermometer/sight glass)
- ✓ Switching outputs
- ✓ Analogue signal

Level

The position of the float is continually captured in fine steps (≥ 5 mm) and shown on the display in mm or inches. Because of continual capture of the level, there is no longer the danger from „stickiness“ of individual mechanical contacts. This substantially increases the operational safety of the installation being monitored.

With the selectable percentage display, the fullness status is shown in a uniform manner to the operator independently of the tank shape. An offset (difference from probe to tank bottom) can also be input so that the level up from the tank bottom can be shown realistically.

With the menu-driven level switching points, the most varied of applications can be conveniently achieved, or be subsequently corrected.

Because switching points no longer have to be notified at the time of ordering, this reduces the large variety of mechanical level switches which are usually needed.

Temperature

The temperature of the medium is continually captured and shown on the display. Just as with the LevelController, all the switching outputs can be set individually. In this connection, all the convenient switch functions such as window and hysteresis, normally-closed and normally-open contacts and also an analogue output for temperature, are of course available.

Reliable/safe

A password enables unauthorised parameter changes to be avoided.

Universal

In combination with convenient switch functions such as hysteresis and window, and normally closed and normally open contacts, intelligent settings can be achieved with the **LevelController**; these are not possible with mechanical level switches. This means that several switches can be replaced by a single Controller. In addition, with the optional analogue outputs there is the possibility of monitoring levels even more conveniently with a single control.

Level: eg. leakage monitoring

Temperature: eg. cooler, heating, warning, switch off.

SCLSD

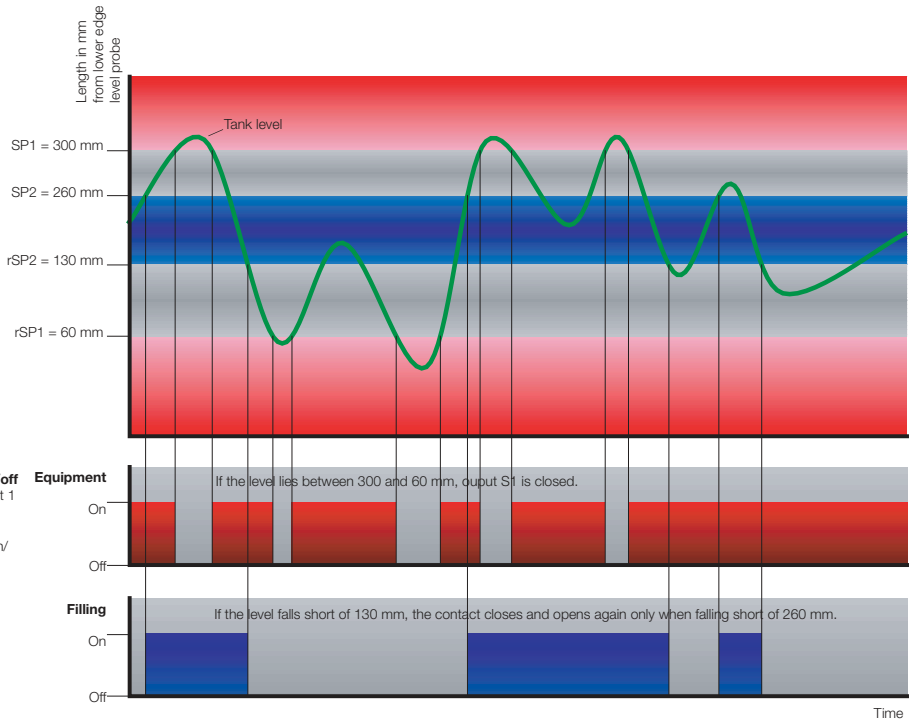

Application example see page 59.

SCTSD

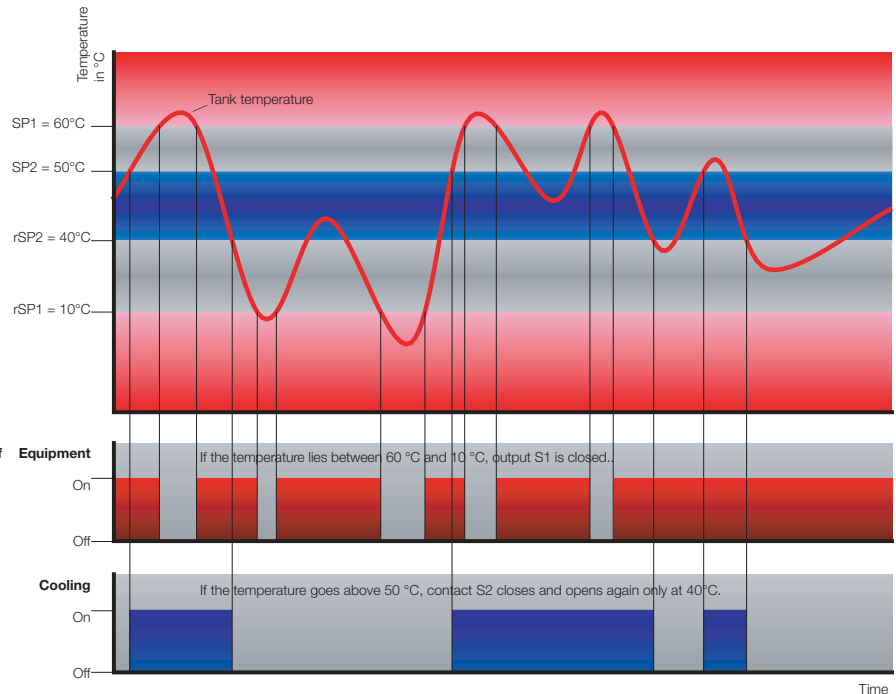

Application example see page 47.

- ✓ Optical interface
- ✓ Switch status display

Everything in view

- ✓ Angled display
- ✓ Digital display
 - ✓ Large
 - ✓ Luminescent
- ✓ Display
 - ✓ mm/inch/%
 - ✓ Actual level
- ✓ High & low display
- ✓ Temperature display
 - ✓ °C/°F
 - ✓ Actual temperature

Easy to operate

- ✓ 3 large keys
- ✓ Display of units

Connect as required

- ✓ 2 switching outputs
- ✓ Analogue output
- ✓ 0...20 or 4...20 mA
- ✓ Freely programmable
- ✓ Scaleable
- ✓ M12 plug –in connector



Rugged

- ✓ Metal housing
- ✓ Watertight
- ✓ High interference resistance
- ✓ Vibration-proof
- ✓ Shock-proof

- ✓ Settable with ControllerWIN software

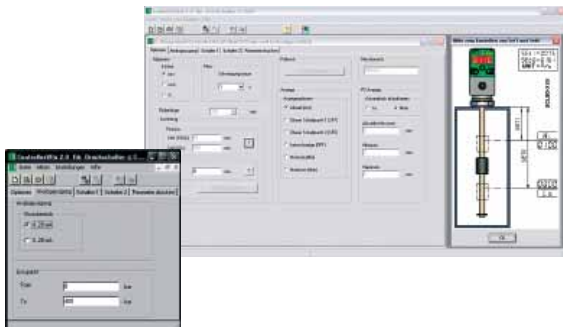

Twin concept

- ✓ 2 in 1

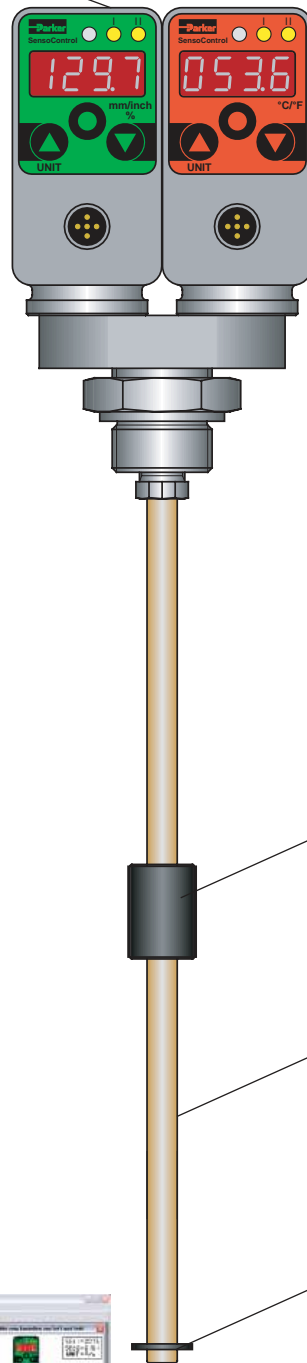

Connect as required

- ✓ One connecting bore
- ✓ Compact
- ✓ 290° rotatable
- ✓ G3/4 BSPP
- ✓ DIN flange

Level

- ✓ Proven measurement system
- ✓ High float dynamics
- ✓ Small construction
- ✓ Universal applicability

No surge tube required

- ✓ Electronic damping
- ✓ Damping settable

Temperature probe

- ✓ integrated into rod end

Electrical connection	
power supply	15...30 VDC nominal 24 VDC; protection class 3
electrical connection	M12x1; 4-pole; 5-pole; with gold-plated contacts
short circuit protection	yes
reverse polarity protection	yes
overload protection	yes
current consumption	< 100 mA
Housing	
	directionally adjustable up to 290°
material	zinc die-casting Z 410; painted
foil material	polyester
display	4-figure 7-segment LED; red; digit height 9 mm
protection class	IP67 DIN EN 60529
Environmental conditions	
Environmental temperature range	-20...+85 °C
storage temperature range	-40...+100 °C
EM compatibility	
interference emissions	EN 61000-6-3
interference resistance	EN 61000-6-2
Outputs	
switching outputs	2 MOSFET high side switches (PNP)
contact functions	normally-open/normally-closed; window/hysteresis; function freely settable
switch voltage	power supply -1,5 VDC
switch current max.	0,5 A per switch
short circuit current	2,4 A per switch
analogue output	0/4...20 mA; programmable; freely scaleable; RL ≤ (power supply - 8 V)/ 20 mA (≤ 500 Ω)

Level	
Input quantities	
measurement element	resistance reed array with float
connection thread	G3/4 BSPP; nickel-plated brass; ED soft seal NBR*
parts in contact with media	brass; nickel-plated brass; NBR*
temperature range of medium	-20...+85 °C
media compatibility	water; lubricating oil; hydraulic oil; acids; alkalis
Output quantities	
switch point accuracy	± 1 % FS at 25 °C
display accuracy	± 1 % FS ± 1 digit at 25 °C
response speed	≤ 700 ms
resolution	7,5 mm
Float	
material	NBR
dimensions	Ø 18 mm, length 35 mm
Level rod	
material	brass
dimensions	Ø 8 mm
working pressure	1 bar
Temperatur	
Input quantities	
display range	-50...150 °C; (-58...+302 °F)
probe input	PT1000
probe connection	M12x1; 4-pole
Output quantities	
switch point accuracy	± 0,35 % FS bei 25 °C
display accuracy	± 0,35 % FS ± 1 digit at 25 °C
response speed	≤ 300 ms

*other seal materials (FKM, EPDM etc.) on request

Percentage display example

mm display example

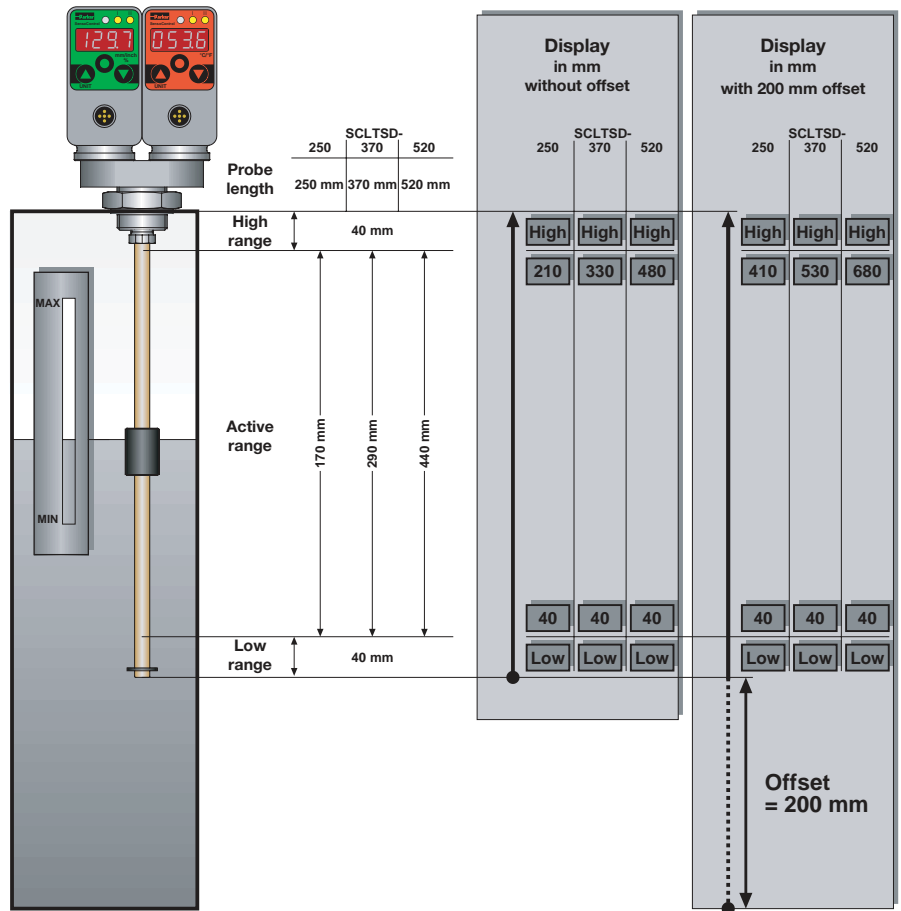
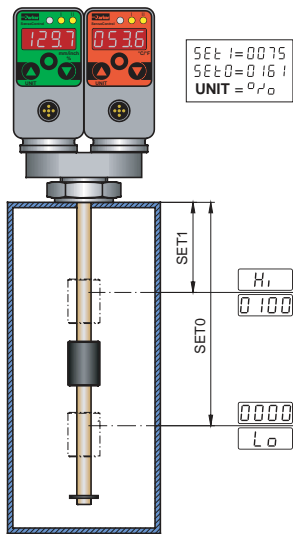

L1 Probe length measurement range	L2 Active range	Display resolution increment	Increment	Smallest reverse switch value RSP	Greatest switch value SP	Smallest settable distance between SP and RSP (SP-RSP)
250 mm	40...210 mm	1 mm	5 mm	40	210	5 mm
370 mm	40...330 mm	1 mm	5 mm	40	330	5 mm
520 mm	40...480 mm	1 mm	5 mm	40	480	5 mm

Connection designation

SCLTSD-xxx-00-07 temperature/level respectively
2 switching outputs;
M12x1; 4-pole



SCLTSD-xxx-10-07 temperature/level respectively
1 switching output; 1 analogue output;
M12x1; 4-pole

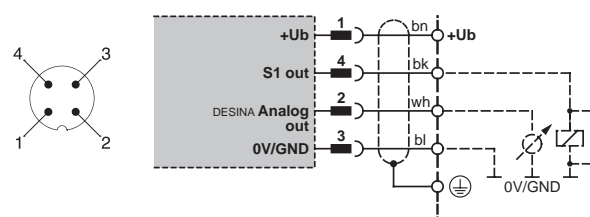
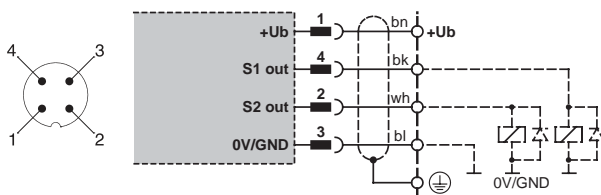

bn = brown bk = black wh = white bl = blue

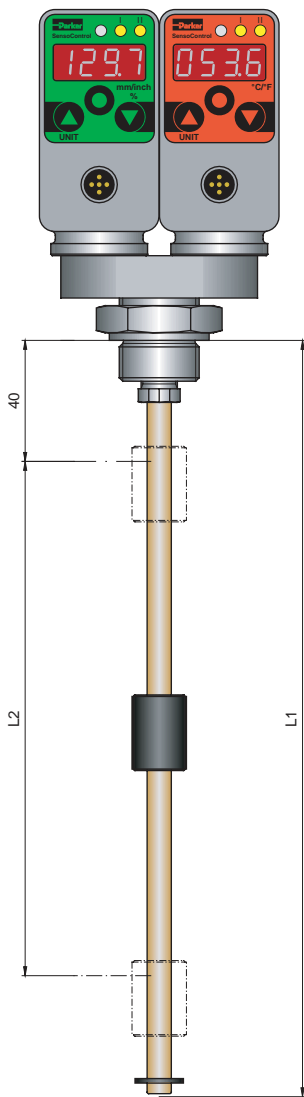

L1 = probe length
L2 = active range

SCLTSD LevelTempController

built-in length (L1) 250/370/520 mm	SCLTSD-xxx-00-07
<u>level</u> 2 switching outputs; without analogue output M12x1; plug-in connector; 4-pole <u>Temperature</u> 2 switching outputs; without analogue output M12x1; plug-in connector; 4-pole	
<u>Level</u> 1 switching output; with analogue output M12x1; plug-in connector; 4-pole <u>Temperature</u> 1 switching output; with analogue output M12x1; plug-in connector; 4-pole	SCLTSD-xxx-10-07
<u>Level</u> 2 switching outputs; with analogue output M12x1; plug-in connector; 5-pole <u>Temperature</u> 2 switching outputs; with analogue outputs M12x1; plug-in connector; 5-pole	SCLTSD-xxx-10-05

Accessories

PC Programming kit	SCSD-PRG-KIT
Flange adaptor, 6-hole connection DIN 24557, part 2	SCAF-3/4-90

Connecting cable & separate plugs

Connecting cable, made up	SCK-400-xx-xx
(open cable end)	
Cable length in m	
02 2 m	_____
05 5 m	_____
10 10 m	_____
Plug-in connector	
45 M12 cable socket; straight	_____
55 M12 cable socket; 90° angled	_____

SCLTSD-xxx-10-05 temperature/level respectively

2 switching outputs; 1 analogue output;
M12x1; 5-pole

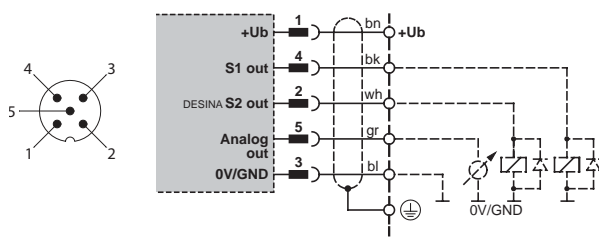

Separate plugs

M12 cable socket; straight	SCK-145
M12 cable socket; 90° angled	SCK-155

4.5 SCOTC OilTankController

- ✓ Proven measurement system
- ✓ Level/temperature display
- ✓ mm/inch/% display
- ✓ High & low display
- ✓ Only one bore
- ✓ Continual level measurement
- ✓ Connection:
 - filler coupling
 - air filter
 - low pressure
- ✓ No surge tube required



Additionally to the **LevelTempController**, the **OilTank-Controller** offers standardised connections for an air filter and a filler coupling.

It is exactly in this area of tank monitoring for series users that the integration of level and temperature, in combination with the air filter and filling adaptor connector, reveals its potential in a unique way. Also, only one connecting bore is required for four functions.

The OilTankController combines the functions of a level/temperature switch, a level/temperature sensor and a level/temperature display:

- ✓ Level/temperature display (thermometer/sight glass)
- ✓ Switching outputs
- ✓ Analogue signal

Level

The position of the float is continually captured in fine steps (≥ 5 mm) and shown on the display in mm or inches. Because of continual capture of the level, there is no longer the danger from “stickiness” of individual mechanical contacts. This substantially increases the operational safety of the installation being monitored.

With the selectable percentage display, the fullness status is shown in a uniform manner to the operator, independently of the tank shape. An offset (difference from probe to tank bottom) can also be input so that the level up from the tank bottom can be shown realistically.

With the menu-driven level switching points, the most

varied of applications can be conveniently achieved, or be subsequently corrected.

Because switching points no longer have to be notified at the time of ordering, this reduces the large variety of mechanical level switches which are usually needed.

Temperature

The temperature of the medium is continually captured and shown on the display. Just as with the LevelController, all the switching outputs can be set individually. In this connection, all the convenient switch functions such as window and hysteresis, normally-closed and normally-open contacts and also an analogue output for temperature, are of course available.

Reliable/safe

A password guarantees that unauthorised changing of parameters can be avoided.

Universal

In combination with convenient switch functions such as hysteresis and window, and normally closed and normally open contacts, intelligent settings can be achieved with the **LevelController**; these are not possible with mechanical level switches. This means that several switches can be replaced by a single Controller. In addition, with the optional analogue output there is the possibility of monitoring levels more conveniently with a single control.

Level: eg. leakage monitoring

Temperature: eg. cooler, heating, warning, switch off

SCLSD



Equipment on/off
 Switching output 1
 SP1 = 300 mm
 rSP1 = 60 mm
 Window function/
 normally open

Fill tank
 Switching output 2
 SP2 = 260 mm
 rSP2 = 130 mm
 Hysteresis/
 normally closed

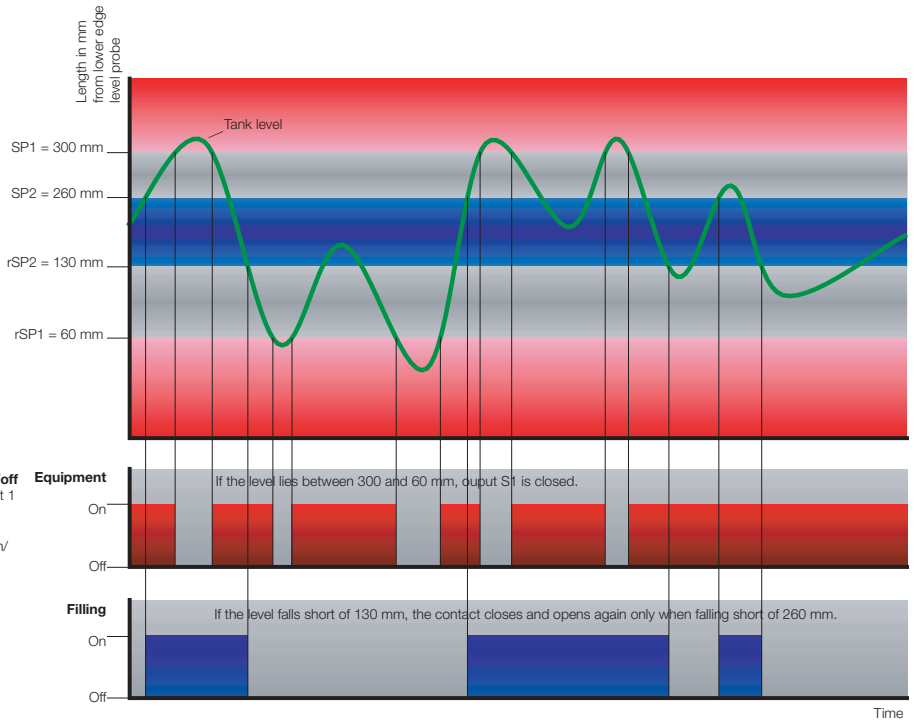

Application example see page 59.

SCTSD



Equipment on/off
 Switching output 1
 SP1 = 60 °C/
 rSP2 = 10 °C
 Window function/
 normally open

Cooling
 Switching output 2
 SP2 = 50 °C/
 rSP2 = 40 °C
 Hysteresis/
 normally open

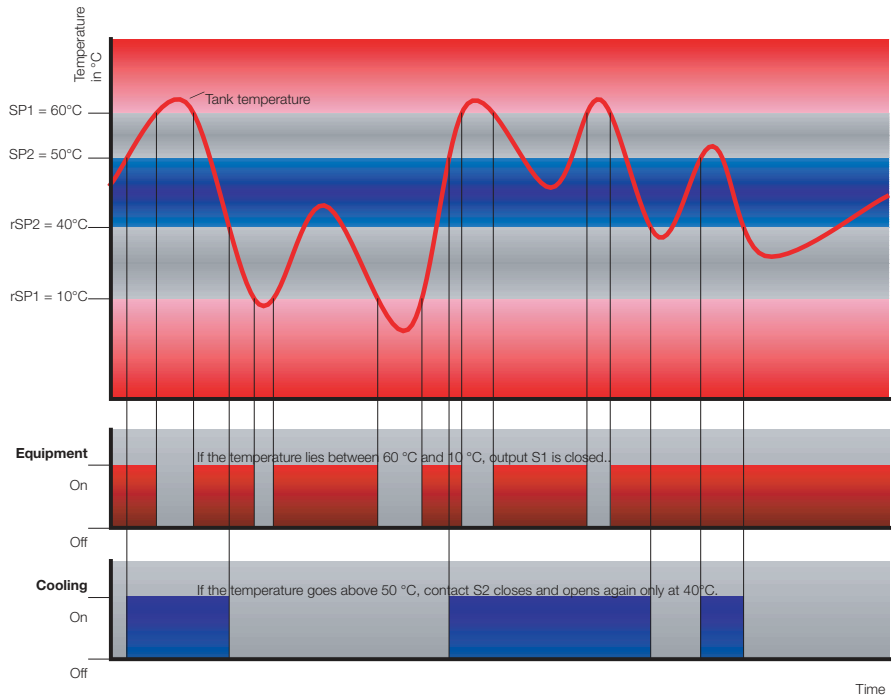

Application example see page 47.

Getting to the point

- ✓ Compact construction (4 in 1)
- ✓ Simple switching point setting via menu
- ✓ Analogue output
- ✓ Safety Control
- ✓ Cost savings in logistics, assembly and maintenance

Level/Temperature

- ✓ Display
- ✓ Settable switching output
- ✓ Analogue output

For expanded version with Safety Control

- ✓ Additional fixed switch contacts
 - ✓ Level min/max
 - ✓ Temperature too high

Real fullness status

The LevelController continually measures the position of the float and shows this position continuously on the display.
 ✓ up to 1000 mm

Temperature sensor

Connections

6-hole standard DIN 24557, part 2 for
 ✓ Breather filter*

G3/4 BSPP for
 ✓ Filling coupling*

G1/8 BSPP for
 ✓ Under-pressure switch
 ✓ Contamination display*

6-hole standard DIN 24557, part 2 for
 ✓ Tank connection

Filler tube

No surge tube required
 ✓ electronic damping/
 damping settable

No whirl action

✓ "Whirl-up protection"

✓ Settable with **ControllerWIN software**



* Breather filter, filler coupling, underpressure switch and contamination display are **not included** in our supply programme.

SCOTC	250	370	520	800	1000
tank built-in length	250 mm	370 mm	520 mm	800 mm	1000 mm
setting range	40...210 mm	40...330 mm	40...480 mm	40...760 mm	40...960 mm

Electrical connection	
power supply	15...30 VDC nominal 24 VDC; protection class 3
electrical connection	M12x1; 4-pole; 5-pole; with gold-plated contacts
short circuit protection	yes
reverse polarity protection	yes
overload protection	yes
current consumption	< 100 mA
Housing	
material	zinc diecasting Z 410; painted
foil material	polyester
display	4-figure 7-segment LED; red; digit height 9 mm
protection class	IP67 DIN EN 60529
Environmental conditions	
environmental temperature range	-20...+80 °C
storage temperature range	-40...+100 °C
scanning interval	300 ms
display refreshment	1 s
EM compatibility	
interference emissions	EN 61000-6-3
interference resistance	EN 61000-6-2
Outputs	
switching outputs	2 MOSFET high side switches (PNP)
contact functions	normally-open/normally-closed; win- dow/hysteresis; function freely settable
switch voltage	power supply -1,5 VDC
switch current max.	0,5 A per switch
short circuit current	2,4 A per switch
Optional analogue output	
measurement range	0/4...20 mA; programmable
response speed (0 bis 95%)	≤ 300 ms
error	± 1 % FS
working resistance	≤ 500 Ω from $U_b > 18$ VDC

Level	
Input quantities	
measurement element	resistance reed array
connection thread	6-hole standard DIN 24557, part 2
Output quantities	
switch point accuracy	± 1 % FS at 25 °C
display accuracy	± 1 % FS ± 1 digit at 25 °C
response speed	≤ 700 ms
resolution	5 mm to 520 mm; 10 mm > 520
Float	
material	polypropylene
dimensions	Ø 35 mm; length 40 mm
Level rod	
material	brass
dimensions	Ø 12 mm
working pressure	1 bar max.
Optional Lo-Hi contact (S3 out)	
alarm contact	switched in series Lo and Hi normally- closed contact
maximum load current	0,7 A
Temperatur	
Input quantities	
display range	-50...150 °C; (-58...+302 °F)
probe element	PT1000
filler tube	Ø 18x1 mm
response time	$\tau_{0,9} = 60$ s
Output quantities	
switch point accuracy	± 0,5 % FS at 25 °C
display accuracy	± 0,5 % FS ± 1 digit at 25 °C
response speed	≤ 300 ms
Optional thermo-switch (S3 out)	
alarm contact at > 65 °C	normally-closed contact
maximum load current	0,7 A

Connection designations

without Safety Control output

SCOTC-xxxx-00-07 temperature/level respectively
2 switching outputs; M12x1; 4-pole

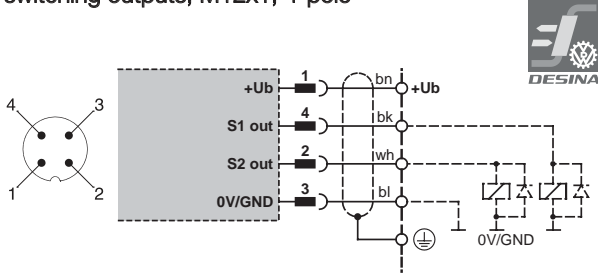

SCOTC-xxxx-10-07 temperature/level respectively
1 switching output; 1 analogue output; M12x1; 4-pole

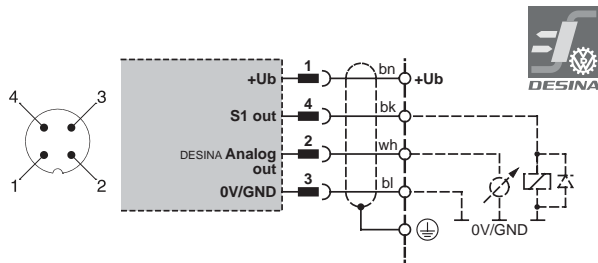

SCOTC-xxx-10-05 temperature/level respectively
2 switching outputs; 1 analogue output;
M12x1; 5-pole

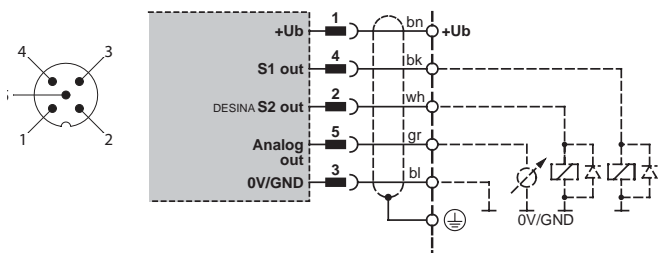

Connection designation

with Safety Control output

SCOTC-xxxx-00-05

Level:

2 variable switching outputs;

1 fixer Safety Control output level min/max; M12x1; 5-pole

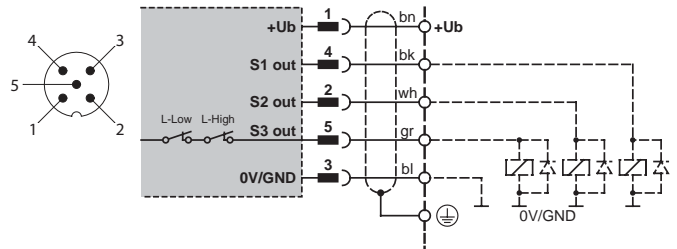

Temperature:

2 variable switching outputs;

1 fixer Safety Control output temperature max (65 °C);

M12x1; 5-pole

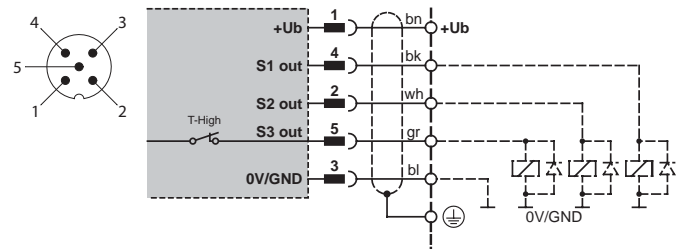

bn = brown wh = white gr = grey
bk = black bl = blue

L1 Probe length measurement range	L2 Active range	Display resolution increment	Increment	Smallest reverse switch value RSP	Greatest switch value SP	Smallest settable distance between SP and RSP (SP-RSP)
250 mm	170 mm	1 mm	5 mm	40	210	5 mm
370 mm	290 mm	1 mm	5 mm	40	330	5 mm
520 mm	440 mm	1 mm	5 mm	40	480	5 mm
800 mm	720 mm	1 mm	10 mm	40	760	10 mm
1000 mm	920 mm	1 mm	10 mm	40	960	10 mm

See also example page 68.

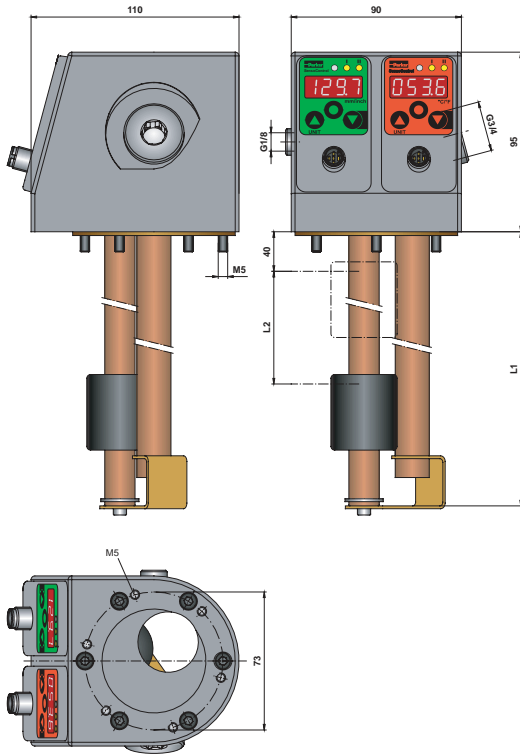

SCOTC OilTankController *

built-in length (L1)
250/370/520/800/1000 mm

Level
2 switching outputs; without analogue output
M12x1; plug-in connection; 4-pole

Temperature
2 switching outputs; without analogue output
M12x1; plug-in connection; 4-pole

Level
1 switching output; with analogue output
M12x1; plug-in connection; 4-pole

Temperature
1 switching output; with analogue output
M12x1; plug-in connection; 4-pole

Level
2 switching outputs; with analogue output
M12x1; plug-in connection; 5-pole

Temperature
2 switching outputs; with analogue output
M12x1; plug-in connection; 5-pole

Level with Safety Control
3 switching outputs; without analogue output
M12x1; plug-in connection; 5-pole

Temperature with Safety Control
3 switching outputs; without analogue output
M12x1; plug-in connection; 5-pole

SCOTC-xxxx-00-07

SCOTC-xxxx-10-07

SCOTC-xxxx-10-05

SCOTC-xxxx-00-05

Connecting cable & separate plugs

Connecting cable, made up **SCK-400-xx-xx**
(open cable end)

Cable length in m

02 2 m _____

05 5 m _____

10 10 m _____

Plug-in connector

45 M12 cable socket; straight _____

55 M12 cable socket; 90° angled _____

Separate plugs

M12 cable socket; straight **SCK-145**

M12 cable socket; 90° angled **SCK-155**

PC programming kit

SCSD-PRG-KIT

* Breather filter, filler coupling, underpressure switch and contamination display are **not included** in our supply programme.

- ✓ One cable for all requirements
- ✓ Compact
- ✓ Interference-proof
- ✓ Compatible with sensors & Controllers
- ✓ M12 plug
- ✓ DIN EN 175301 (appliance inlet connector)
- ✓ Various lengths

SensoControl® cables were designed in accordance with the requirements of industrial sensors and switches.

M12 cables and M12 plugs are therefore generally

- ✓ compact
- ✓ screened
- ✓ 5-pole

5-pole type

The 5-pole cables are suitable for both 4 and 5-pole connections. The 5-pole cables are fully compatible with with sensor variants having a 4-pole plug.

Consequently, despite the varying numbers of pins for the pressure switches (Controller family SCxSD & SCOTC) and sensors, a 5-pole cable can always be used independently of the plug version.

SCK-400-xxx-x5 cables fit all the components with an M12 plug-in connection.

Screening

Interference and working safety are guaranteed thanks to screening.

- ✓ High EMC protection

Connecting cable
SCK-400-xx-45

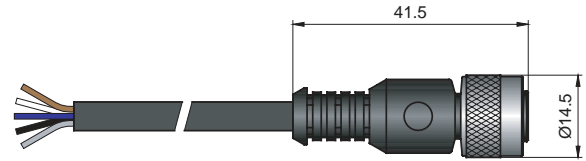

SCK-400-xx-55

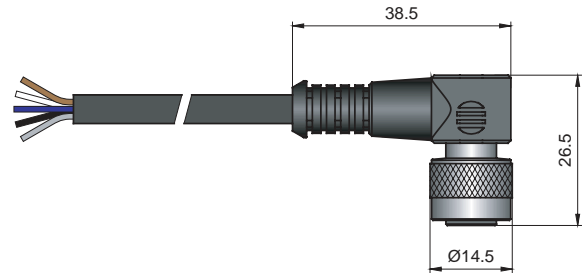

SCK-400-xx-x5			
PIN			
1	bn	brown	braun
2	wh	white	weiß
3	bl	blue	blau
4	bk	black	schwarz
5	gr	grey	grau

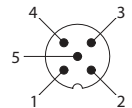

SCK-400-xx-56

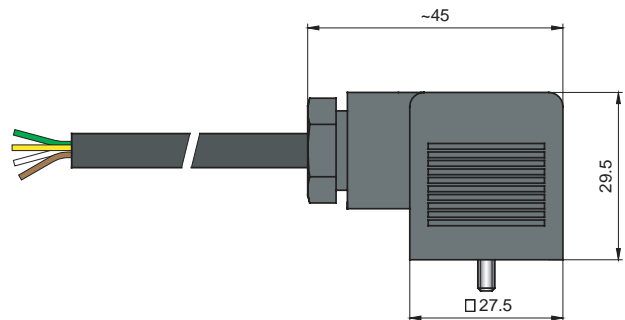

SCK-400-xx-56			
Pin			
1	ye	yellow	gelb
2	gn	green	grün
3	bn	brown	braun



Separate plugs

SCK-145

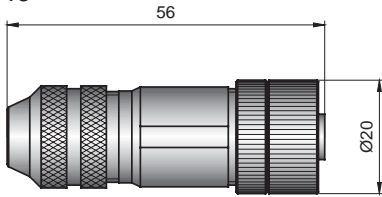

SCK-155

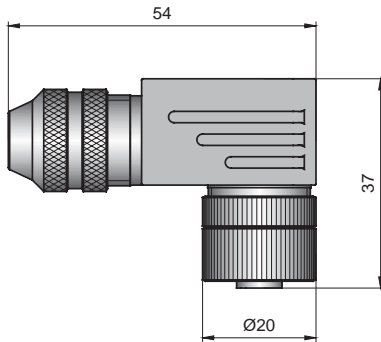

SCK-006
(appliance inlet connector)

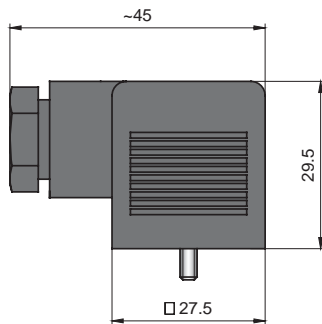

Connecting cable & separate plugs

Connecting cable, made up

SCK-400-xx-xx

(open cable end)

Cable length in m

02 2 m

05 5 m

10 10 m

Plug-in connector

45 M12 cable socket; straight

55 M12 cable socket; 90° angled

56 DIN EN 175301-803 form A plug connector
(formerly DIN 43650)

Separate plugs

M12 cable socket; straight

SCK-145

M12 cable socket; 90° angled

SCK-155

DIN EN 175301-803 form A plug
connector (formerly DIN 43650)

SCK-006

SCA-1/4 reducing adaptor

SCA-1/4-M22x1.5-ED
SCA-1/4-ED-1/2-ED

guarantees compatibility with earlier sensor versions with M22x1,5 or G1/2 BSPP hydraulic connections

- ✓ For replacing predecessor versions

In this way equipment can be brought up to the very latest level without a great deal of time being needed on planning.

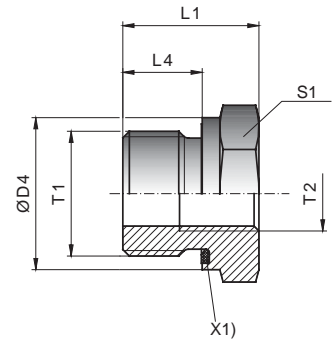

X1) EOLASTIC sealing

T1	T2	ØD4	L1	L4	S1	Weight (g per piece)	Ordering code*	PN (bar) ¹⁾ A3C	DF **
M22x1.5	G1/4 BSPP	27	24	14	27	56	SCA-1/4-M22x1.5-ED	400	4
G1/2 BSPP	G1/4 BSPP	27	24	14	27	56	SCA-1/4-ED-1/2-ED	400	4

SCA-1/4 damping adaptor

SCA-1/4-EDX-1/4-D

Pressure peaks caused by the system are reduced with the SCA-1/4-EDX-1/4-D.

- ✓ Damping of pressure peaks

The G1/2 BSPP type also guarantees compatibility with earlier sensor versions with the G1/2 BSPP hydraulic connection

- ✓ For replacing predecessor versions

(If stronger damping is required, an SMA3-xxxx diagnostic hose should be used in addition)

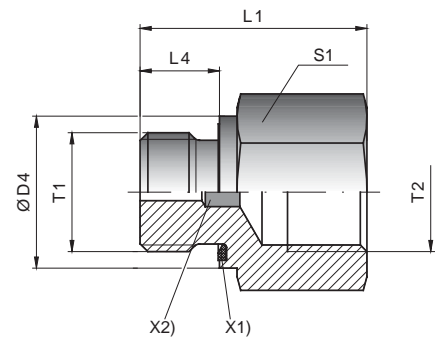

X1) EOLASTIC sealing
X2) damping element

T1	T2	ØD4	L1	L4	S1	Weight (g per piece)	Ordering code*	PN (bar) ¹⁾ A3C	DF **
G1/4A BSPP	G1/4 BSPP	19	34	12	22	61	SCA-1/4-EDX-1/4-D	630	3,5

SCPSD flange adaptor SCAF-1/4-40 for mechanical switches

SCAF-1/4-40

for replacing existing mechanical pressure switches with a 40x40 mm flange connection.

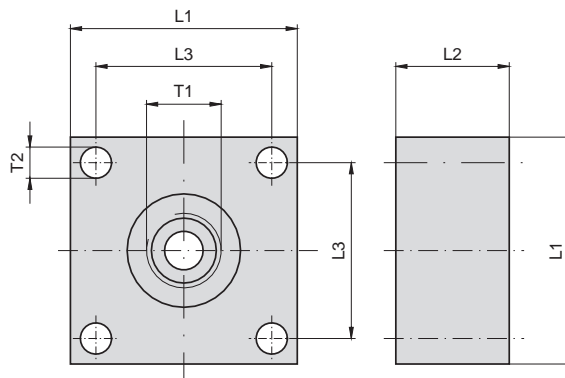

T1	T2	L1	L2	L3	Weight (g each)	Ordering code*	PN (bar) ¹⁾ Alu	DF **
G1/4 BSPP	5,5	40	20	31	15	SCAF-1/4-40	400	4

SCLSD/SCLTSD flange adaptor SCAF-3/4-90 6-hole DIN 24557 part 2 connection

SCAF-3/4-90

For Level and LevelTemp Controllers(SCLSD und SCLTSD) this guarantees compatibility with the 6-hole DIN 24557, part 2 tank connection.

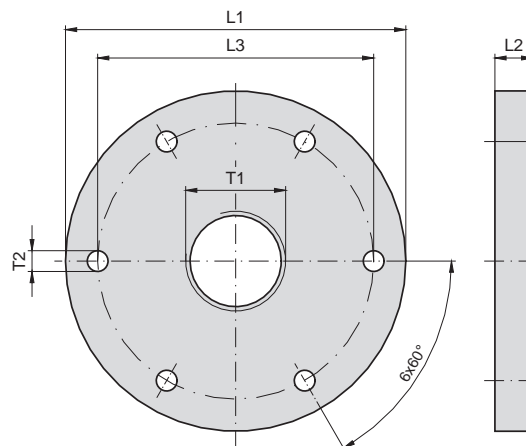

T1	T2	L1	L2	L3	Weight (g each)	Ordering code*	Material
G3/4 BSPP	5,5	90	10	73	520	SCAF-3/4-90	nickel-plated brass

** DF = Design Factor (safety factor)

5.3 ControllerWIN software

- ✓ Suitable for Controller family
- ✓ Simple setting of all parameters
- ✓ Parameter saving
- ✓ Setting with a PC/Laptop
 - ✓ at the workbench
 - ✓ on the desk
 - ✓ at the installation

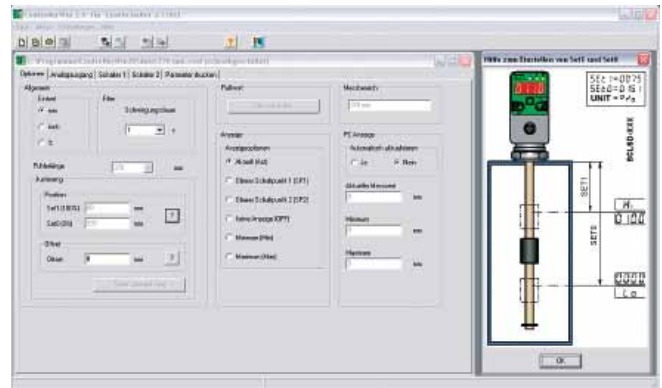

ControllerWIN software makes the setting and saving of all parameters possible, eg.

- ✓ Switching points
- ✓ Normally-closed and normally-open contact functions
- ✓ Window/hysteresis function
- ✓ Scaling of analogue output
- ✓ Passwords
- ✓ etc...

From the Controller family product range:

- ✓ SCPSD
- ✓ SCTSD
- ✓ SCLSD
- ✓ SCLTSD
- ✓ SCOTC

Function

By means of a contact-less infra-red interface, data are synchronised with respective Controllers which are ready to function. This can take place directly in the installation or externally by means of a power pack (supplied with the delivery package).

- ✓ No interruption of power supply (pulling out the cable) necessary (interference-free operation)

For this purpose a programming adaptor is connected to the respective Controller and the data can then be transferred to a PC.

The SCSD-PRG_KIT programming kit includes all the components (adaptor, software and power pack) needed to set up the Controller anywhere with a PC/laptop.

- ✓ at the workbench
- ✓ on the desk
- ✓ at the installation

Application

- ✓ Saving and documenting set values
- ✓ Programming of several Controllers
- ✓ Easy replacement of existing Controller

In all these cases the programming kit is the ideal solution.

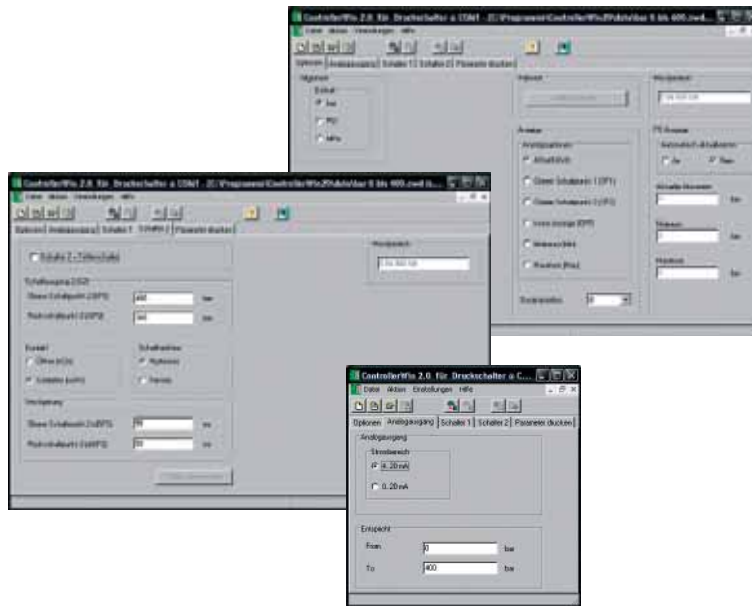

Accessory for:

PressureController	TemperatureController	LevelController	LevelTempController	OilTankController
pressure display and monitoring	temperature display and monitoring	level display and monitoring	level/temperature display and monitoring	

System prerequisites	
operating system	WIN 98/2000/ME/NT/XP
PC/laptop connection	RS232 (USB with a standard adaptor)
Controller connection	Parker SCxSD/SCOTC infra-red interface

Ordering code

PC programming kit

SCSD-PRG-KIT

6. Installation and safety advice



The CE mark indicates high-quality equipment which meets European Directives 89/336/EWG and EMVG requirements respectively.

It is hereby confirmed that the products are in accordance with the following standards:

6.1 Electromagnetic compatibility

- Electromagnetic interference emissions: EN 61000-6-3
- Electromagnetic interference resistance: EN 61000-6-2

Important

- Electromagnetic interference can influence the useful signal.
- General EMC concepts should be used in the designing of installations and machinery.
- To achieve better EMC interference resistance, the deployment of screened connecting cables is recommended (SCK-400-xx-x5).
- Route analogue and data cables at a safe distance from power cables.
- A perfect earthing arrangement helps to avoid measurement errors.

Always connect the metallic housing with the laid-down quantities. The PE protective earth terminal should be connected up with a low ohm value. Measurement of the protective earth resistance should take place in accordance with VDE 0701.

Power supply:

The recommended power supply with which each standard sensor should be driven is indicated for the individual sensor series. A low-noise, high quality, constant voltage source is recommended. Some specifications, such as sensitivity and thermal sensitivity shift, change if a supply voltage is used which is not recommended. Every sensor is tuned to give peak performance. Usage with any other than the indicated power supply leads to a change in sensor performance. All polarity and earthing regulations should be strictly followed.



Improper connection of the supply wires can cause damage to the sensor or amplifier!

If one pole of the sensor supply voltage is earthed automatically by a signal processing system, a simultaneous earthing of one of the sensor signal wire should be avoided; this would short-circuit the sensor and thereby lead to damage.



Do not connect a power supply to the output wires; this would lead to permanent damage to the sensor!

Exceeding the maximum recommended supply voltage indicated in the data sheet would also lead to sensor damage!

6.2 Media compatibility

SensoControl® products in contact with media are not produced in an oil and grease-free environment.

Therefore these products should **not** be used for applications where an explosive oil or oil/gas mixture could occur (eg. acid or compression). (Danger of explosion!)

Use only those media which are compatible with the parts in contact with the media (see data sheets).

If you should have any questions, please refer to the installation manufacturer or to the manufacturer of the medium being used (see catalogue 4100 chapter C).

6.3 Selection of pressure range

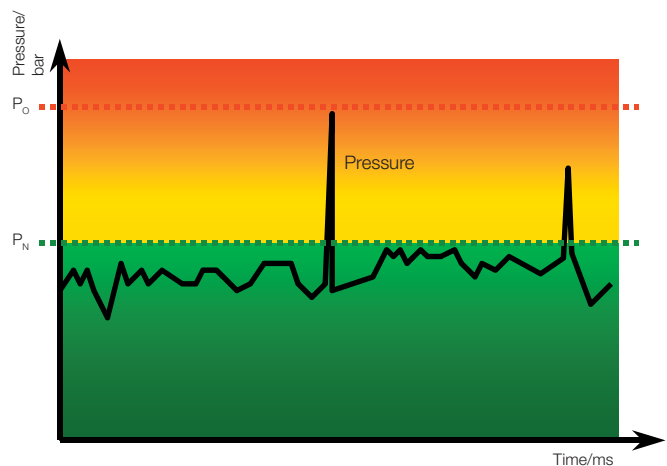

When selecting pressure elements do not exceed the overload pressure P_{max} .

If the overload pressure P_{max} is exceeded, mechanical deformation of the pressure cell (according to the length/frequency and height of the pressure peak) can result.

Note: where there are air inclusions, because of the "diesel effect" pressure peaks can occur which far exceed the overload pressure.

The nominal pressure P_N of the pressure element (sensor/switch) should lie above the nominal pressure of the system being measured.



Parker Hannifin Corporation

About Parker Hannifin Corporation

Parker Hannifin is a leading global motion-control company dedicated to delivering premier customer service.

A Fortune 500 corporation listed on the New York Stock Exchange (PH), our components and systems comprise over 1,400 product lines that control motion in some 1,000 industrial and aerospace markets.

Parker is the only manufacturer to offer its customers a choice of hydraulic, pneumatic, and electromechanical motion-control solutions. Our Company has the largest distribution network in its field, with over 7,500 distributors serving nearly 400,000 customers worldwide.

Parker's Charter

To be a leading worldwide manufacturer of components and systems for the builders and users of durable goods.

More specifically, we will design, market and manufacture products controlling motion, flow and pressure. We will achieve profitable growth through premier customer service.

Product Information

Customers seeking product information, the location of a nearby distributor, or repair services will receive prompt attention by calling the Parker Product Information Centre.

The Centre can be called toll free from France, Germany, Austria, Switzerland or the United Kingdom. You will be answered by a Parker employee in your own language. Call Freephone: 00800-2727-5374 (00800 C PARKER H).

The Aerospace Group

is a leader in the development, design, manufacture and servicing of control systems and components for aerospace and related high-technology markets, while achieving growth through premier customer service.



The Climate & Industrial Controls Group

designs, manufactures and markets system-control and fluid-handling components and systems to refrigeration, air-conditioning and industrial customers worldwide.



The FluidConnectors Group

designs, manufactures and markets rigid and flexible connectors, and associated products used in pneumatic and fluid systems.



The Seal Group

designs, manufactures and distributes industrial and commercial sealing devices and related products by providing superior quality and total customer satisfaction.



The Hydraulics Group

designs, produces and markets a full spectrum of hydraulic components and systems to builders and users of industrial and mobile machinery and equipment.



The Filtration Group

designs, manufactures and markets quality filtration and clarification products, providing customers with the best value, quality, technical support, and global availability.



The Automation Group

is a leading supplier of pneumatic and electromechanical components and systems to automation customers worldwide.



The Instrumentation Group

is a global leader in the design, manufacture and distribution of high-quality critical flow components for worldwide process instrumentation, ultra-high-purity, medical and analytical applications.



Parker Fluid Connectors Group Europe

Parker Hannifin Ges.mbH
A-2700 Wiener Neustadt
Tel: +43 2622 23501
Fax: +43 2622 66212

Parker Hannifin Corporation
AE-Abu Dhabi
Tel: +971 2 6788587
Fax: +971 2 6793812

Parker Hannifin Corporation
AZPAR - Techn. Repr. for
Parker Hannifin plc
AZ-1000 Baku
Tel/Fax: +994 12 4983966

Parker Hannifin S.A.-N.V.
B-1400 Nivelles
Tel: +32 67280900
Fax: +32 67280999

Parker Hannifin s.r.o.
CZ-250 67 Klecany
Tel: +420 2 84083111
Fax: +420 2 84083112

Parker Hannifin GmbH & Co. KG
D-41564 Kaarst
Tel: +49 2131 4016-0
Fax: +49 2131 4016-9199

Parker Hannifin Danmark A/S
DK-2750 Ballerup
Tel: +45 43560400
Fax: +45 43733107

Parker Hannifin España S.A
E-28850 Torrejón de Ardoz (Madrid)
Tel: +34 91 6757300
Fax: +34 91 6757711

Parker Hannifin Corporation
EG-Cairo
Tel: +20 2 5194018
Fax: +20 2 5190605

Parker Hannifin France SAS
F-74130 Contamine-sur-Arve
Tel: +33 450258025
Fax: +33 450978660

Parker Hannifin Oy
FI-01510 Vantaa
Tel: +358 207532500
Fax: +358 207532200

Parker Hannifin Ltd.
GB-Derby DE24 8JA
Tel: +44 1332 365631
Fax: +44 1332 368038

Parker Hannifin Corporation
GR-171 21 Athens
Tel: +30 21 0933-6450
Fax: +30 21 0933-6451

Parker Hannifin Corporation
H-1149 Budapest
Tel: +36 1 220-4155
Fax: +36 1 422-1525

Parker Hannifin S.p.A.
I-20094 Corsico (MI)
Tel: +39 02 451921
Fax: +39 02 4479340

Parker Sales Ireland Ltd
IE-Baldonell, Co. Dublin
Tel: +353 1 4666370
Fax: +353 1 4666376

Parker Hannifin Corporation
Gateway Ventures Ca Ltd.
KZ-480100 Almaty
Tel: +7 327 2505800
Fax: +7 327 2505801

Parker Hannifin A/S
N-1402 Ski
Tel: +47 64 91 10 00
Fax: +47 64 91 10 90

Parker Hannifin B.V.
NL-7570 AH Oldenzaal
Tel: +31 541 585000
Fax: +31 541 585459

Parker Hannifin Sp.z o.o.
PL-02-235 Warszawa
Tel: +48 22 5732400
Fax: +48 22 5732403

Parker Hannifin Portugal Lda
PT-4450-625 Leça da Palmeira
Tel: +351 22 9997360
Fax: +351 22 9961527

Parker Hannifin Corporation
Hidro Consulting Impex Srl
RO-021381 Bucharest
Tel: +40 21 2521382
Fax: +40 21 2523381

Parker Hannifin LLC
RU-123083 Moscow
Tel: +7 495 6412156
Fax: +7 495 6121860

Parker Hannifin Corporation
RU-693000 Yuzhno-Sakhalinsk
Tel/Fax: +7 4242 752742

Parker Hannifin AB
SE-16308 Spånga
Tel: +46 8 59795000
Fax: +46 8 59795110

Parker Hannifin Corporation
SI-8000 Novo Mesto
Tel: +386 7 337-6650
Fax: +386 7 337-6651

Parker Hannifin Corporation
TR-34067 Merter/Istanbul
Tel: +90 212 48291-06/07
Fax: +90 212 48291-10

Parker Hannifin Corporation
UA-01004 Kiev
Tel: +380 44 4942731
Fax: +380 44 4942730

Parker Hannifin Africa
ZA-Kempton Park
Tel: +27 11 9610700
Fax: +27 11 3927213

Internet: http://www.parker.com/euro_tfd

**For further information on other Parker Products, call the European Product Information Centre
free of charge on 00800 2727 5374.**



CAT/4083-2/UK
© 2007 Parker Hannifin/0207
Aktuell 0207